



REV.	DESCRIPTION	NAME	DATE

NOTE:

1.MATERIAL SPECIFICATION:

- 1.HOUSING: LCP
- 2.CONTACTS: C2680,T=0.15mm
- 3.MID PLATE: SUS301,T=0.15mm
- 4.INSIDE SHELL: SUS304,T=0.30mm
- 5.OUTSIDE SHELL: SUS304,T=0.25mm

2.PLATING SPECIFICATION:

- 2-1.CONTACTS:  
Ni 50u" MIN. UNDER PLATED OVER ALL.  
Au PLATED ON THE FUNCTIONAL AREA OF CONTACT.  
GOLD FLASH PLATING ON CONTACT AREA,  
GOLD FLASH PLATING ON SOLDER AREA

2-2.OUTSIDE SHELL:

- Ni 30u" MIN. UNDER PLATED OVER ALL.

3.MECHANICAL PERFORMANCE,

- 3-1.INSERTION FORCE: 0.5~2.0kgf.
- 3-2.REMOVAL FORCE: 0.8kgf~2.0kgf.
- 3-3.DURABILITY: 10000 CYCLES.

4.ELECTRICAL PERFORMANCE,

- 4-1. CURRENT RATING: 5A  
VOLTAGE RATING: 20V
- 4-2.INSULATION RESISTANCE: 100MΩ MIN
- 4-3.DIELECTRIC WITHSTAND VOLTAGE,AC 100V FOR 1 MINUTE.
- 4-4.LOW CONTACT RESISTANCE: INITIAL 40MΩ  
AFTER 50MΩ

5. ENVIRONMENTAL PERFORMANCE:

- OPERATING TEMPERATURE: -30°C~+80°C.

6.IR REFLOW:

- THE PEAK TEMPERATURE ON THE BOARD SHALL  
BE MAINTAINED FOR 10 SECONDS AT 260°C.

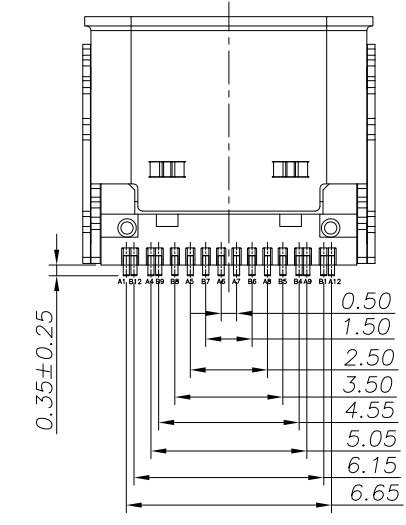
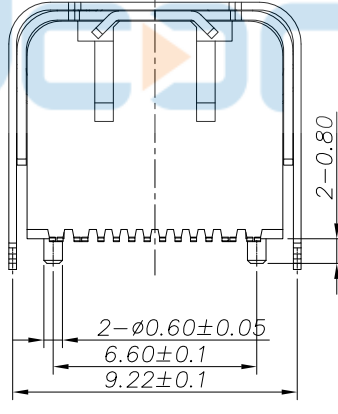
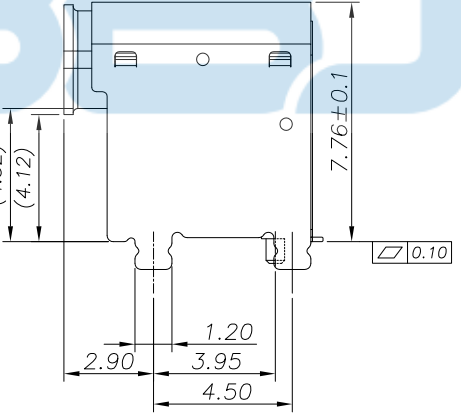
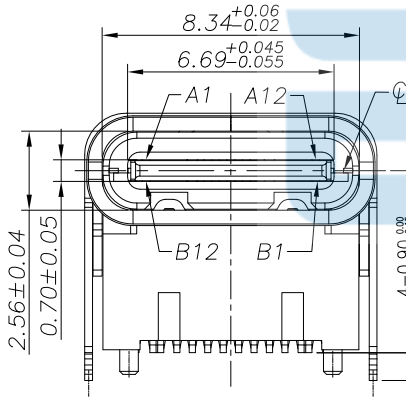
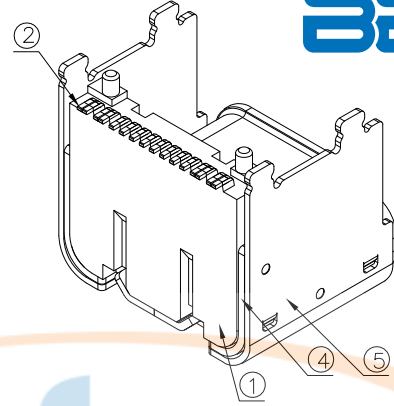
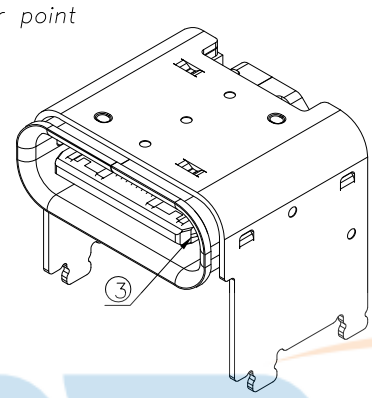
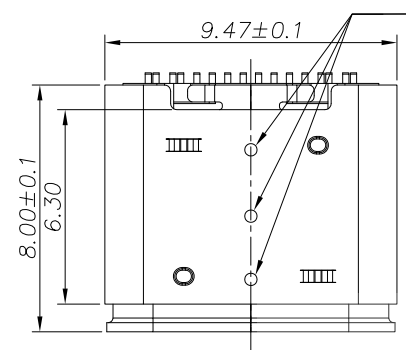

TOLERANCE UNSPECIFIED	
.0	±0.35
.00	±0.25
.000	±0.15
X. °	±2.00°
CUSTOMER DRAWING	

**深圳市步步精科技有限公司**

TITLE:  
TYPE-C 16PIN 母座板上垫高4.3MM L=8.0 CH5.90外壳两个焊点

DRAWN/ DATE	HMY	SIZE:A4	UNIT:MM.	PART. NO:	UC.01.51-11-0019
CHECKED/ DATE	LYX	SCALE: 1:1	PROJECTION	REV.:	版本
APPROVED/ DATE	LJP	DWG. PATH	0100-2	SHEET:	页码



USB TYPE-C PIN ASSIGNMENTS

PIN NUMBER	SIGNAL NAME	PIN NUMBER	SIGNAL NAME
A1	GND	B12	GND
A4	VBUS	B9	VBUS
A5	CC1	B8	SBU2
A6	Dp1	B7	Dn2
A7	Dn1	B6	Dp2
A8	SBU1	B5	CC2
A9	VBUS	B4	VBUS
A12	GND	B1	GND

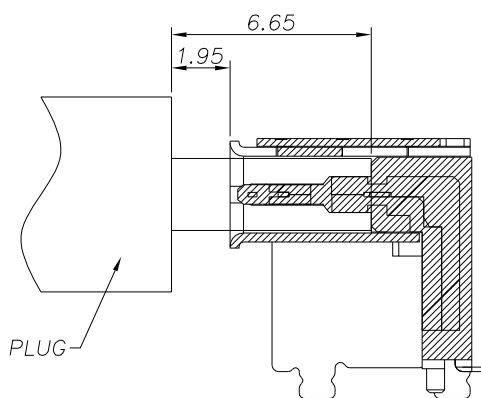
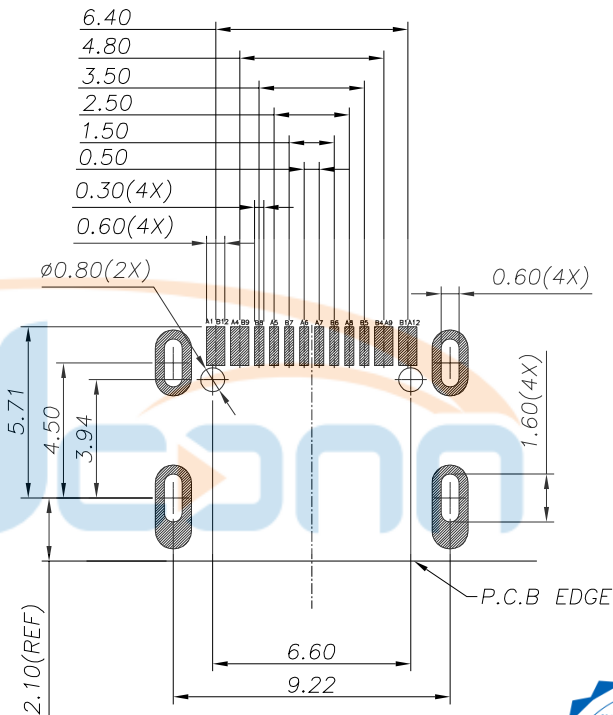

AFTER MATING  
SCALE 1:1



RECOMMEND P.C.B LAYOUT (COMPONENT SIDE)  
TOLERANCE FOR PCB LAYOUT IS  $\pm 0.05$

TOLERANCE UNSPECIFIED		深圳市步步精科技有限公司 TITLE: TYPE-C 16PIN 母座板上垫高4.3MM L=8.0 CH5.90						
.0	$\pm 0.35$							
.00	$\pm 0.25$	DRAWN/ DATE	HMY	SIZE: A4	UNIT: MM.	PART. NO:	UC.01.51-11-0019	
.000	$\pm 0.15$	CHECKED/ DATE	LYX	SCALE: 1:1	PROJECTION			REV.: 版本
X.°	$\pm 2.00^\circ$	APPROVED/ DATE	LJP	DWG. PATH	0100-2		SHEET: 页码	
CUSTOMER DRAWING								

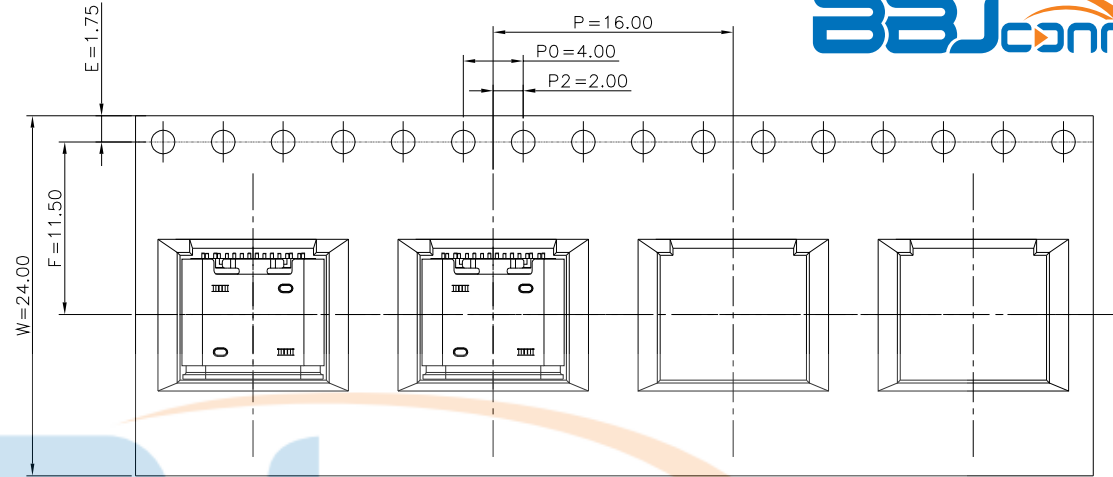
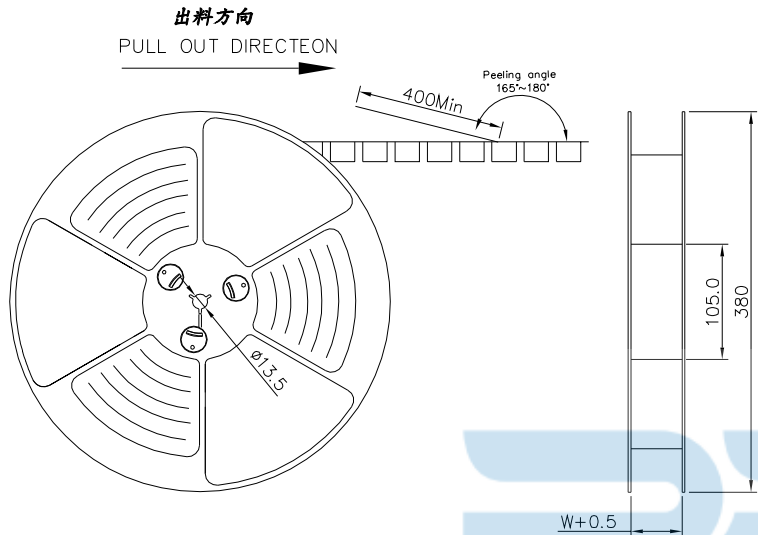

NOTES

1. 帶子引導長度  
LEAD TAPE LENGTH

出料方向  
PULL OUT DIRECTEON

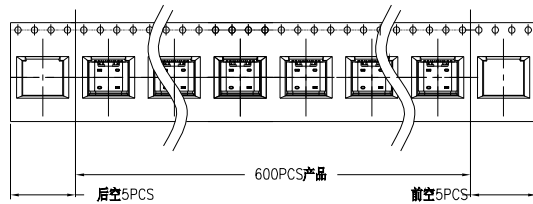

2. 上帶 剝力力為: 0.1~1.3N(10.2gf~130gf)  
PEELING OFF FORCE OF TOP TAPE: 0.1~1.3N(10.2gf~130gf)

出貨運輸過程中一定注意:  
THIS REQUIREMENT SHOULD BE APPLIED AT SHIPMENT:  
卷帶在運輸過程中不能散開  
PEELING OFF SHOULD NOT BE ALLOWED DURING TRANSPORTATION

TAPE & REEL 6 PCS

1 REEL  
= 600 PCS

BOX

DIMENSIONS:  
39.5X39.5X20

LABEL

1 CARTON  
= 6 REELS  
= 3600 PCS

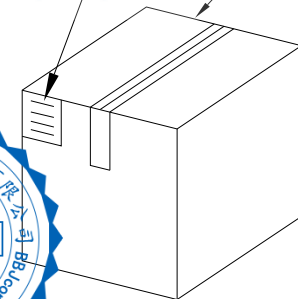
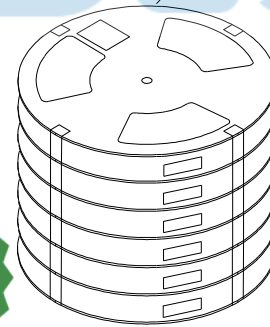

TOLERANCE UNSPECIFIED

.0	±0.35
.00	±0.25
.000	±0.15
X.°	±2.00°
CUSTOMER DRAWING	

深圳市步步精科技有限公司

TITLE: TYPE-C 16PIN 母座板上墊高4.3MM L=8.0 CH5.90

包裝明細表 (The detail of the packing) Carton						
產品料號 (Product No.)	包裝容量 (Packing Capacity)		重量 Weight (Kg)			
	pcs/box	boxs/Carton	Pcs/Box	N.W./Pcs	N.W./Box	G.W./Box
	600	6	3600	----	----	----

DRAWN/ DATE	HMY	SIZE: A4	UNIT: MM.	PART. NO:	UC.01.51-11-0019	
CHECKED/ DATE	LYX	SCALE: 1:1	PROJECTION	REV.: 版本		
APPROVED/ DATE	LJP	DWG. PATH	0100-2		SHEET: 页码	