

REV	ECN NO	CONTENT	DATE	ENGINEER
A0		INITIAL RELEASE	/	SGF

- 备注:
1. 材质:
    - 1.1 胶芯: LCP+30%G. F UL94V-0
    - 1.2 端子: C2680, T=0.20mm; 镀半金锡
    - 1.3 外壳: 不锈钢, T=0.15mm; 表面镀镍
    - 1.4 卡钩: 不锈钢, T=0.40mm; 表面镀锡
  2. 主要特性:
    - 2.1 额定电流: 3A
    - 2.2 接触阻抗: 40mΩ MAX
    - 2.3 绝缘阻抗: 100MΩ MIN 250V DC
    - 2.4 耐压测试: 100V AC
    - 2.5 沾锡性: 温度245±5℃
    - 2.6 整体插入力: 2.0kgf MAX  
整体拔出力: 0.8kgf MIN  
耐久后拔出力: 0.6kgf MIN
    - 2.7 使用寿命: 10000次
    - 2.8 工作温度: -25℃~+80℃

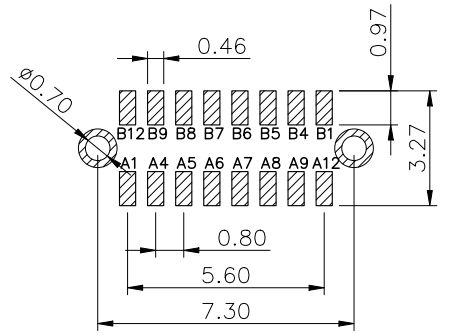

RECOMMENDED P.C.B. LAYOUT

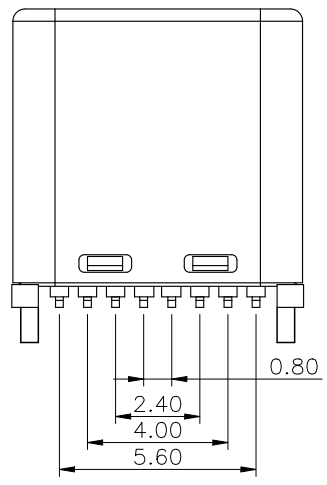
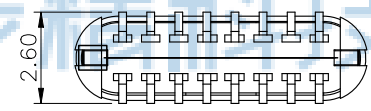
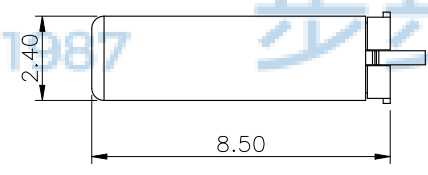
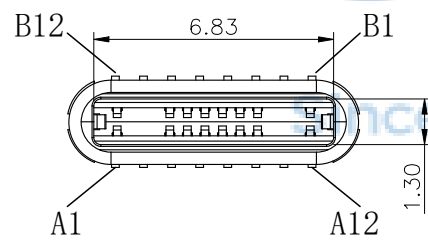
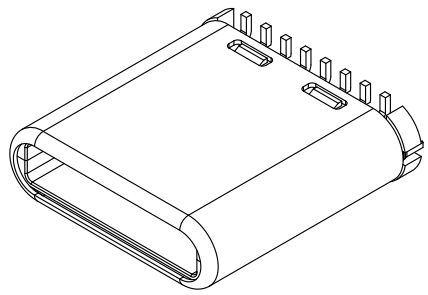
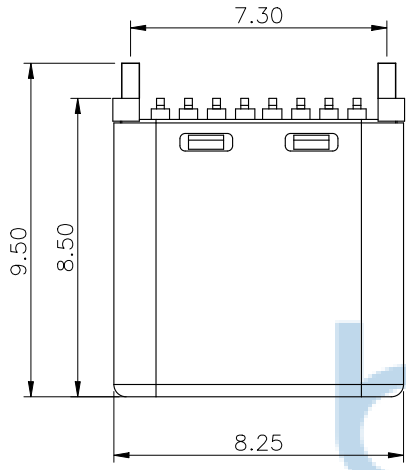

A1	GND	B12	GND
A4	VBUS	B9	VBUS
A5	CC1	B8	SBU2
A6	D+	B7	D-
A7	D-	B6	D+
A8	SBU1	B5	CC2
A9	VBUS	B4	VBUS
A12	GND	B1	GND
PIN	SIGNAL NAME	PIN	SIGNAL NAME

THIS DOCUMENT IS THE SOLE PROPERTY OF BBJconn Technology Co., Ltd. Corporation AND SHOULD NOT BE USED IN WHOLE PRIOR WRITTEN PERMISSION.

PDWG NO: 0366-2

深圳市步步精科技有限公司

NAME: TYPE-C 16P 公头 直立式 贴片 端子SMT H=8.50 卡钩脚距7.3 盒装

APPD	JM_Zheng		PJ NO: 126-124-160002-N5G		
CHKD	LYX		SIZE:A4	DRW NO:	
DR	SGF	FINISH:SEE NOTES	MAT'L:SEE NOTES		
		SCALE:N/A	REV:A0	UNIT:mm	PAGE:1/2

REV	ECN NO	CONTENT	DATE	ENGINEER
A0		INITIAL RELEASE	/	SGF

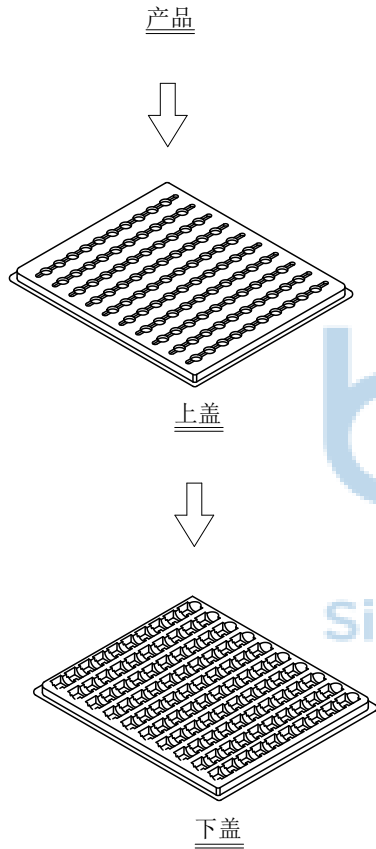

bbJconn  
Since 1987 步步精科技

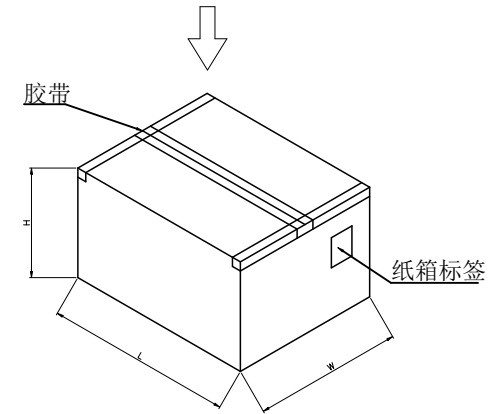
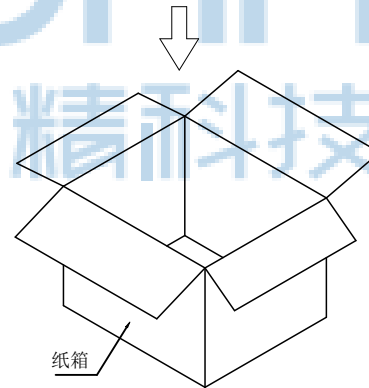
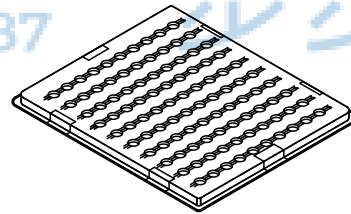

纸箱规格: L350\*W210\*H290

1、包装要求:

- 1.1 每盒吸塑盒包装100pcs;
- 1.2 每20盘放一箱, 共计2000PCS;
- 1.3 纸箱外贴上标签。



THIS DOCUMENT IS THE  
SOLE PROPERTY OF  
BBJconn Technology Co.,Ltd.  
Corporation AND SHOULD  
NOT BE USED IN WHOLE  
PRIOR WRITTEN PERMISSION.

**深圳市步步精科技有限公司**

.X: ±0.38 X': ±3"  
.XX: ±0.25 .X': ±2"  
.XXX: ±0.13 .XX': ±1"

NAME: TYPE-C 16P 公头 直立式 贴片 端子SMT  
H=8.50 卡钩脚距7.3 盒装

APPD JM\_Zheng

PJ NO: 126-124-160002-N5G

CHKD LYX

SIZE:A4 DRW NO:

PDWG NO: 0366-2 DR SGF

FINISH:SEE NOTES MAT'L:SEE NOTES  
SCALE:N/A REV:A0 UNIT:mm PAGE:2/2