

REV.	ECN NO	CONTENT	DATE	ENGINEER
A0				

特性:

- 一、电气性能: ELECTRICAL
 1. 额定电流: 5.0A
 2. 接触阻抗: 40 MILLIOHMS MAX
 3. 耐电压: 150V AC / 1 mA MAX
 4. 绝缘阻抗: 150V DC/100 MEGA OHMS MIN
- 二、机械性能:
 1. 插入力: 5~20N
 2. 拨出力: 8~20N
 3. 使用寿命: 10000次, 拨出力 5N MIN
- 三、材料: MATERIAL
 1. 塑胶: LCP/PA9T UL94V-0
 2. 端子: C7025 C1814 T=0.15MM
 3. 外壳: SUS304 T=0.30MM
 4. 卡勾: SUS304 T=0.15MM
- 四、电镀: FINISH
 1. 端子: 接触点镀金3U~MIN
PIN脚焊接区域镀金1U~MIN.
 2. 外壳: 镀镍80U~MIN (盐雾48H)
- 五、电镀品需做粘锡测试: 粘锡面积达到95%以上.
- 六、SMT回流焊 (峰值260° C±5° C) 不能起泡、
熔胶、变色不良 (变形在公差范围以内)
- 七、工作温度: -55° C~+85° C
- 八、盐雾测试: 通过48H在浓度为5±1%盐水的盐雾
测试无生锈现象

A1	GND	B12	GND
A4	VBUS	B9	VBUS
A5	CC1	B8	SBU2
A6	D+	B7	D-
A7	D-	B6	D+
A8	SBU1	B5	CC2
A9	VBUS	B4	VBUS
A12	GND	B1	GND
PIN	SIGNAL NAME	PIN	SIGNAL NAME

THIS DOCUMENT IS THE
SOLE PROPERTY OF
BBJconn Technology Co.,Ltd.
Corporation AND SHOULD
NOT BE USED IN WHOLE
OR IN PART WITHOUT
PRIOR WRITTEN PERMISSION.
PDWG.NO: 0366-2

深圳市步步精科技有限公司

.X: ±0.38	X': ±3'	NAME:	TYPE-C 16P 母座 直立式 四脚插 端子DIP H=12.40
.XX: ±0.25	.X': ±2'	APPD.	JM_Zheng
.XXX: ±0.13	.XX': ±1'	CHKD.	LYX
DR.	TSP	FINISH:	SEE NOTES
		SCALE:	N/A
		REV.:	A0
		UNIT:	mm
		PAGE:	1/2

REV.	ECN NO	CONTENT	DATE	ENGINEER
AO				

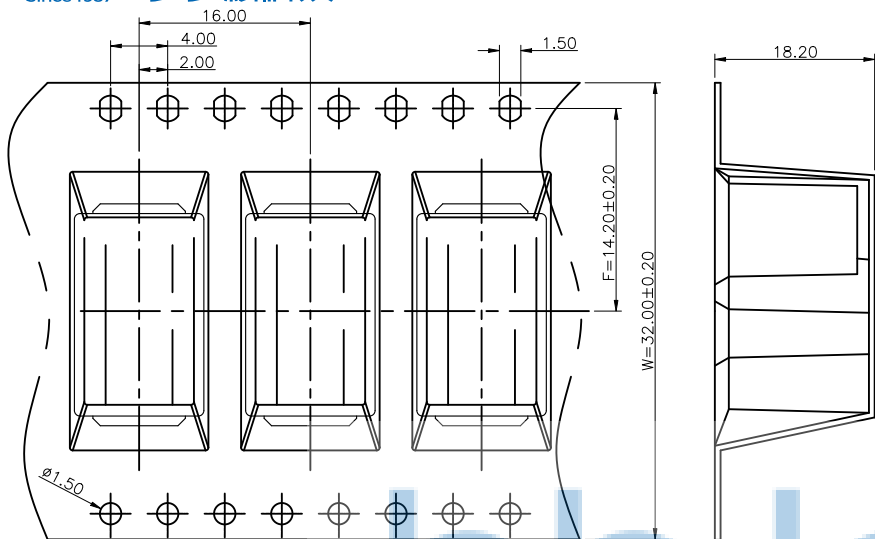

包装说明:

1. 将检验好的成品;焊脚朝下放入载带底部;每卷装370PCS产品;具体如图一所示
2. 将包装好的产品;每盘必需贴上内标签;具体如图二所示
3. 将贴好内标签的产品每8盘叠;具体如图三所示
5. 装好后并封好纸箱及贴好相关标签;具体如图五所示;
(产品包装的标签,如客户有要求,请按客户要求包装出货)
6. 载带前面留5PCS空格,后面留5PCS空格
7. COVER与CARRY剥离力:50-125g,速度:300mm/分钟左右,剥离角度:165°-180°

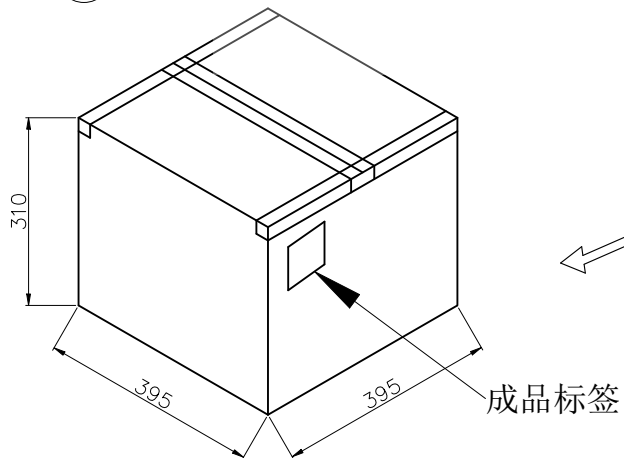
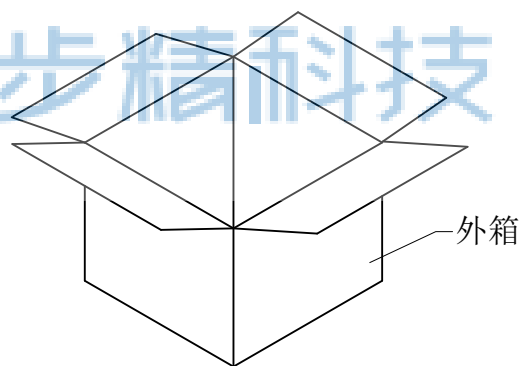
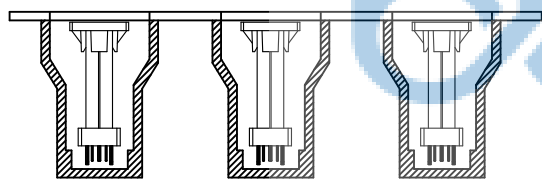
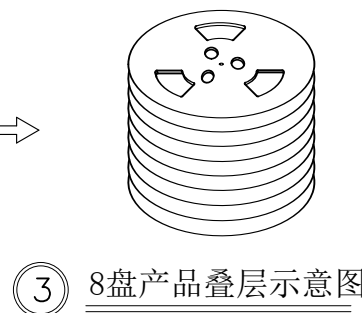
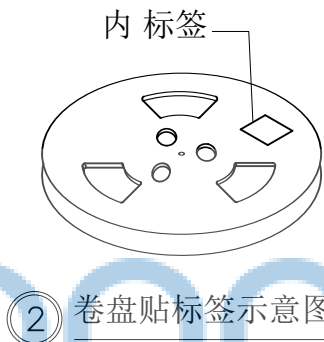

THIS DOCUMENT IS THE SOLE PROPERTY OF BBJconn Technology Co.,Ltd. Corporation AND SHOULD NOT BE USED IN WHOLE OR IN PART WITHOUT PRIOR WRITTEN PERMISSION.		深圳市步步精科技有限公司 .X: ±0.38 .X': ±3" .XX: ±0.25 .X'': ±2" .XXX: ±0.13 .XX': ±1"		NAME: TYPE-C 16P 母座 直立式 四脚插 端子DIP H=12.40 PJ. NO.: 126-225-160012-N5G SIZE: A4 DRW NO.: FINISH: SEE NOTES MAT'L.: SEE NOTES	
APPD.	JM_Zheng			SCALE: N/A REV.: AO UNIT: mm PAGE: 2/2	
CHKD.	LYX	PDWG.NO: 0366-2		DR. TSP	