

REV.	ECN NO.	CONTENT	DATE	ENGINEER
A0		Initial release	/	SGF

NOTE:

- MATERIAL SPECIFICATION:
 - HOUSING: HIGH TEMPERATURE RESISTANT PLASTIC, UL94 V-0.
 - CONTACTS: COPPER ALLOY
 - MID PLATE: STAINLESS STEEL
 - SHELL: STAINLESS STEEL
- PLATING SPECIFICATION:
 - CONTACTS:
 - Ni 50u" MIN. UNDER PLATED OVER ALL.
 - Au PLATED ON THE FUNCTIONAL AREA OF CONTACT.
 - (GOLD PLATING THICKNESS FOLLOW THE P/N)
 - GOLD FLASH PLATING ON SOLDER AREA
 - SHELL:
 - Ni 30u" MIN. UNDER PLATED OVER ALL.
- MECHANICAL PERFORMANCE,
 - INSERTION FORCE: 0.5~2.0kgf.
 - REMOVAL FORCE: 0.8kgf~2.0kgf.
 - DURABILITY: 10000 CYCLES.
- ELECTRICAL PERFORMANCE,
 - CURRENT RATING: 5A
VOLTAGE RATING: 20V
 - INSULATION RESISTANCE: 100MΩ MIN
 - DIELECTRIC WITHSTAND VOLTAGE, AC 100V FOR 1 MINUTE.
 - LOW CONTACT RESISTANCE: INITIAL 40mΩ, AFTER 50mΩ
- ENVIRONMENTAL PERFORMANCE:
 - OPERATING TEMPERATURE: -30°C~+80°C.
 - THE PEAK TEMPERATURE ON THE BOARD SHALL
- IR REFLOW:
 - BE MAINTAINED FOR 10 SECONDS AT 260°C.

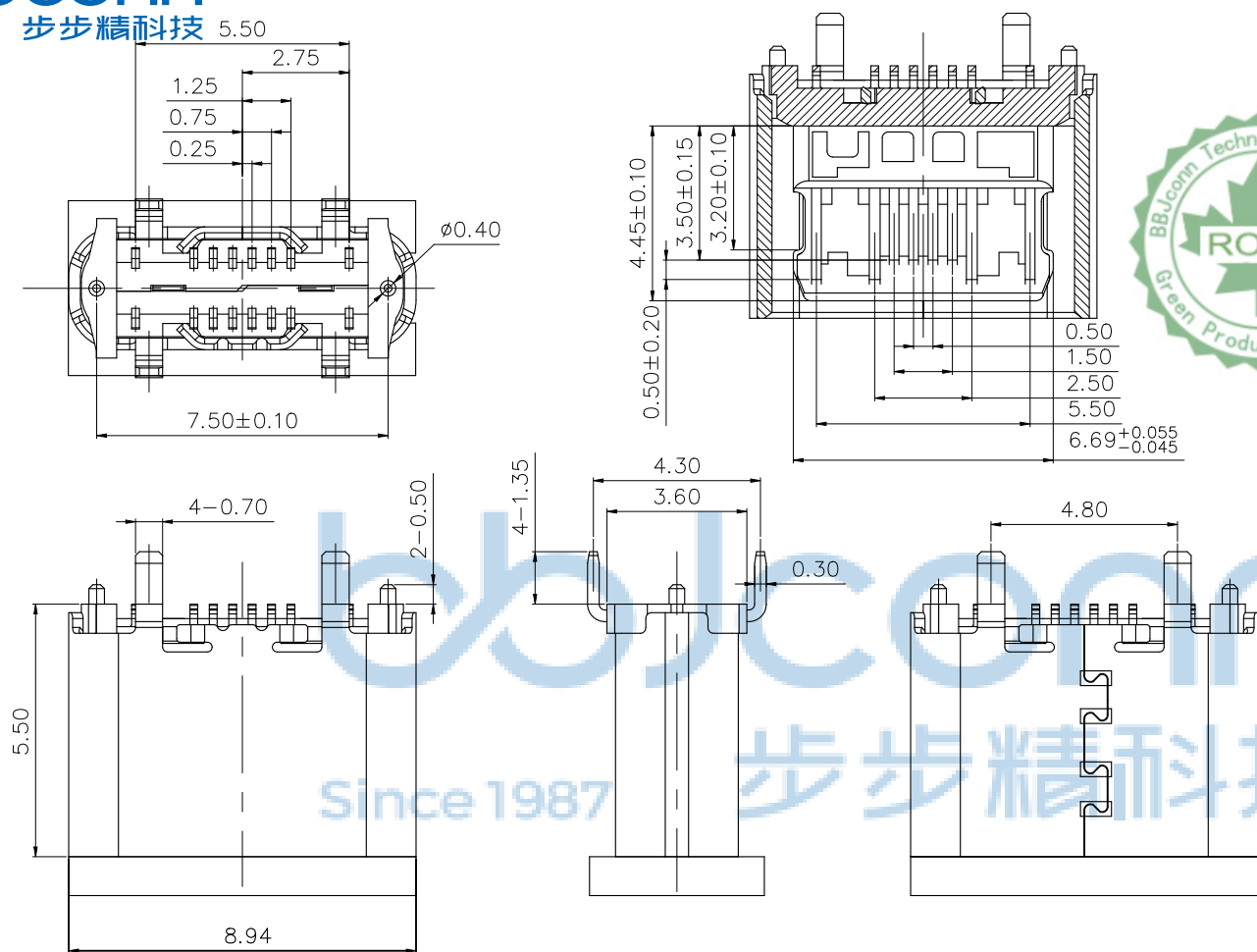

NO.	DESCRIPTION	MATERIAL	REMARKS	QTY
5	CAP	LCP UL94V-0	BLACK	1PCS
4	OUTER SHELL	SUS304 T=0.30MM	NI 30u"MIN	1PCS
3	SHIELDING PLATE	SUS301 T=0.15MM	N/A	1PCS
2	CONTACT	C2680 T=0.15MM	Mating area 1u"Au Solder Tails: G/F Underplate: 50u"Min Ni overall	2SET
1	INSERT MOLDING	LCP UL94V-0	BLACK	1PCS

THIS DOCUMENT IS THE SOLE PROPERTY OF BBJconn Technology Co., Ltd. Corporation AND SHOULD NOT BE USED IN WHOLE OR IN PART WITHOUT PRIOR WRITTEN PERMISSION.

PDWG.NO: 0100-2

深圳市步步精科技有限公司

NAME: TYPE-C 16P 母座 直立式 四脚插 端子SMT 带柱 无弹 H=5.5 大脚(脚长1.35) 编带

PJ. NO.: 126-224-160005-V2G

SIZE: A4DRW NO.:

FINISH: SEE NOTES MAT'L.: SEE NOTES

SCALE: N/A REV.: A0 UNIT: mm PAGE: 1/3

APPD: JM_Zheng

CHKD: LYX

DR: SGF

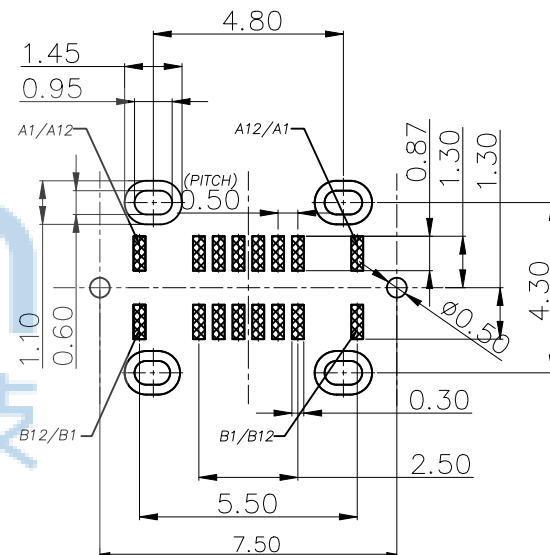
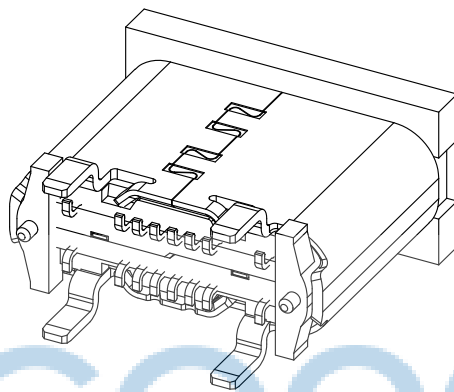

RECOMMENDED P.C.B. LAYOUT
TOLERANCE UNSPECIFIED $\pm 0.05\text{mm}$

USB TYPE-C PIN ASSIGNMENTS

PIN NUMBER	SIGNAL NAME	PIN NUMBER	SIGNAL NAME
A1	GND	B12	GND
A4	VBUS	B9	VBUS
A5	CC1	B8	SBU2
A6	Dp1	B7	Dn2
A7	Dn1	B6	Dp2
A8	SBU1	B5	CC2
A9	VBUS	B4	VBUS
A12	GND	B1	GND



THIS DOCUMENT IS THE
SOLE PROPERTY OF
BBJconn Technology Co.,Ltd.
Corporation AND SHOULD
NOT BE USED IN WHOLE
OR IN PART WITHOUT
PRIOR WRITTEN PERMISSION.
PDWG.NO: 0100-2

深圳市步步精科技有限公司	
.X: ± 0.38 X': $\pm 3^*$.XX: ± 0.25 .X': $\pm 2^*$.XXX: ± 0.13 .XX': $\pm 1^*$	NAME: TYPE-C 16P 母座 直立式 四脚插 端子SMT 带柱 无弹 H=5.5 大脚(脚长1.35) 编带
APPD. JM_Zheng CHKD. LYX DR. SGF	P.J. NO.: 126-224-160005-V2G SIZE: A4 DRW NO.: FINISH: SEE NOTES MAT'L.: SEE NOTES SCALE: N/A REV.: A0 UNIT: mm PAGE: 2/3

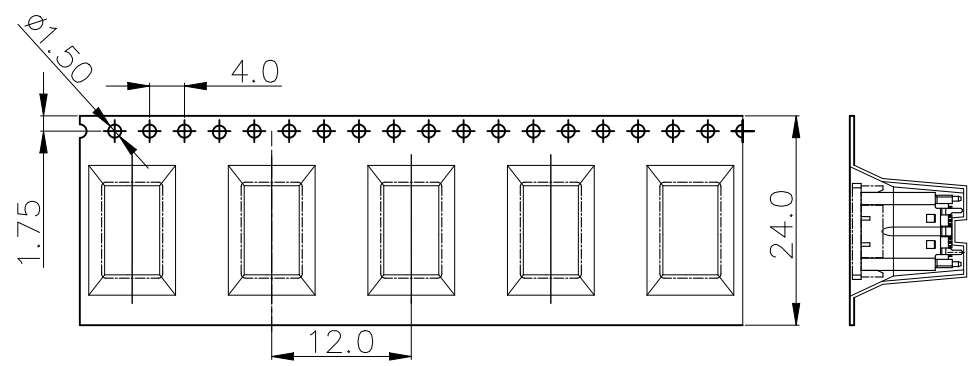
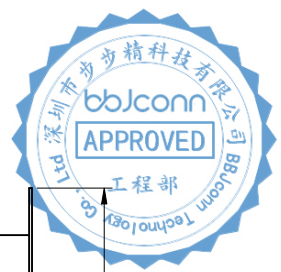
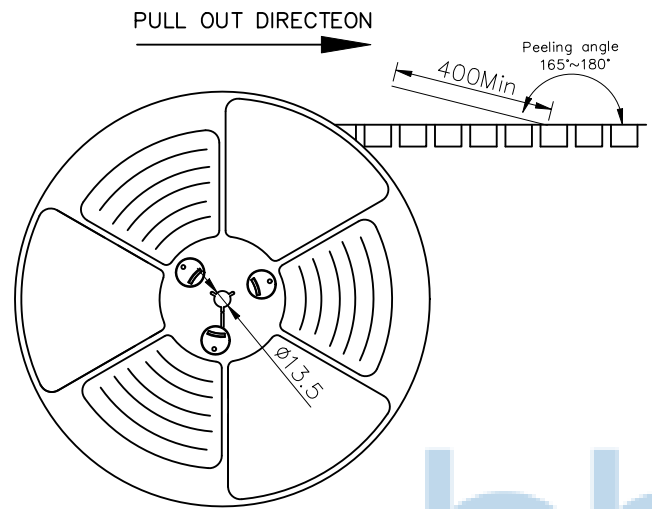

NOTES

1. 帶子引導長度
LEAD TAPE LENGTH
出料方向
PULL OUT DIRECTEON

出料方向
PULL OUT DIRECTEON

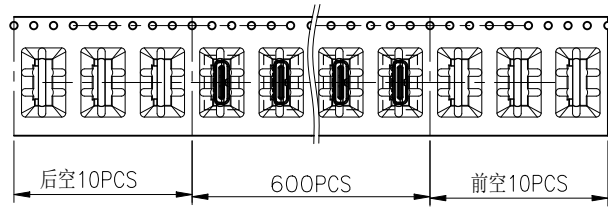

2. 上帶 剝力力為 : 0.1~1.3N(10.2gf~130gf)
PEELING OFF FORCE OF TOP TAPE: 0.1~1.3N(10.2gf~130gf)
出貨'運輸過程中一定注意:
THIS REQUIREMENT SHOULD BE APPLIED AT SHIPMENT:
卷帶在運輸過程中不能散開
PEELING OFF SHOULD NOT BE ALLOWED DURING TRANSPORTATION

TAPE & REEL 10 PCS
1 REEL = 600 PCS

BOX
DIMENSIONS:
33.5X33.5X30.5

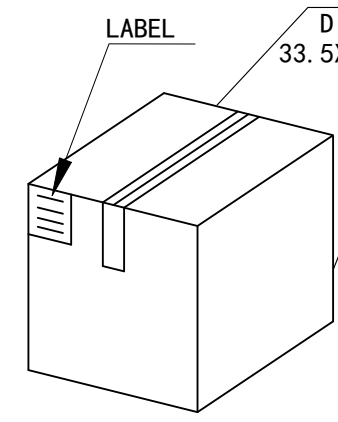
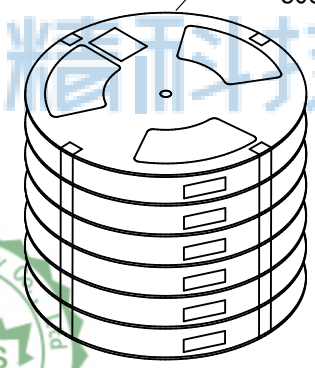

1 CARTON
=10 REELS
=6000 PCS



包裝明細表 (The detail of the packing)						
產品料號 (Product No.)	包裝容量Packing Capacity)			重量 Weight (Kg)		
	pcs/box	boxes/Carton	Pcs/Box	N. W. /Pcs	N. W. /Box	G. W. /Box
	600	10	6000	---	---	---

THIS DOCUMENT IS THE SOLE PROPERTY OF BBJconn Technology Co.,Ltd.
Corporation AND SHOULD NOT BE USED IN WHOLE OR IN PART WITHOUT PRIOR WRITTEN PERMISSION.
PDWG.NO: 0100-2

bbJconn 深圳市步步精科技有限公司

.X: ±0.38	X': ±3'	NAME:	TYPE-C 16P 母座 直立式 四脚插 端子SMT 带柱 无弹 H=5.5 大脚(脚长1.35) 编带
.XX: ±0.25	.X': ±2'	APPD:	JM_Zheng
.XXX: ±0.13	.XX': ±1'	CHKD:	LYX
		DR.	SGF

PJ. NO.: 126-224-160005-V2G
SIZE: A4 DRW NO.:
FINISH: SEE NOTES MAT'L.: SEE NOTES
SCALE: N/A REV.: A0 UNIT: mm PAGE: 3/3