

REV.	ECN NO	CONTENT	DATE	ENGINEER
AO				

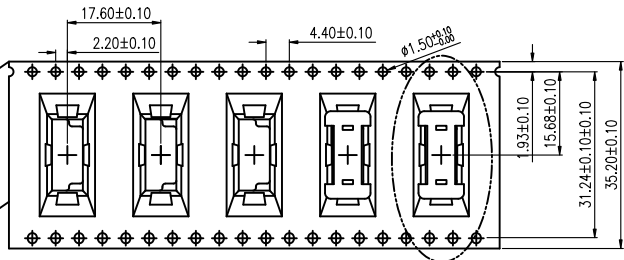

NOTES

1. NUMBER OF CONNECTORS:300PCS/REEL
2. LEAD TAPE LENGTH

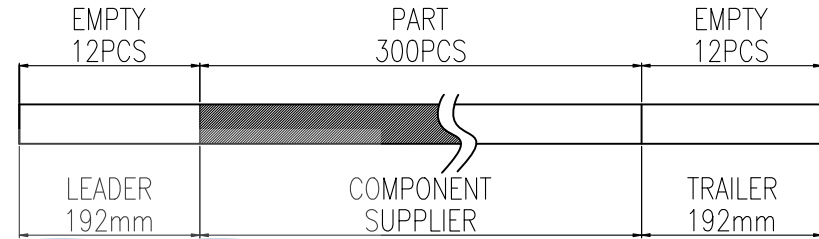

3. QUANTITY:2400/CARTON
4. WEIGHT :
 - 4.1 NET WEIGHT : 2.62 Kg
 - 4.2 GROSS WEIGHT : 6.6 Kg

A
B
C
D
E

A
B
C
D
E

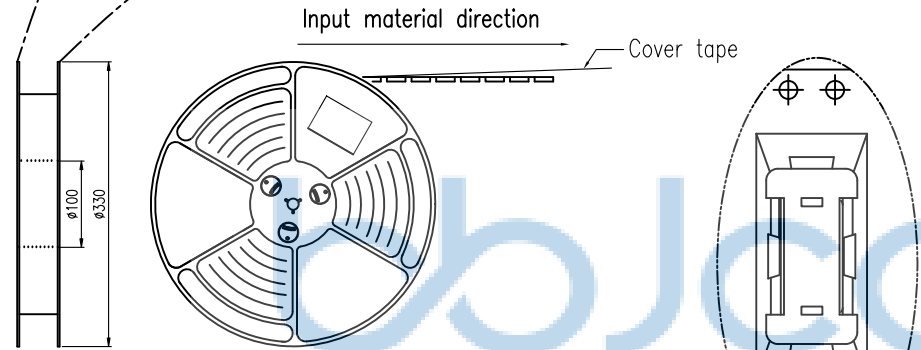

Note: You should put two desiccants in each PE bag

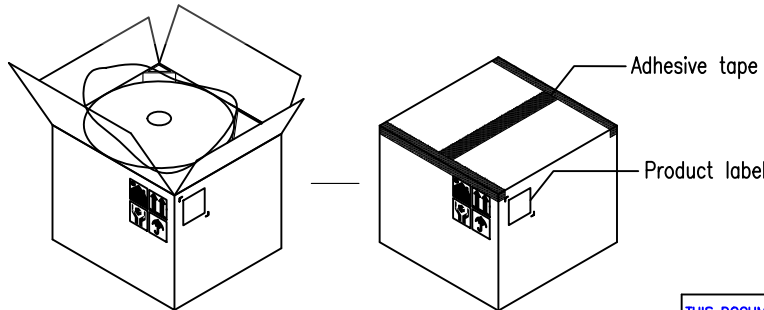
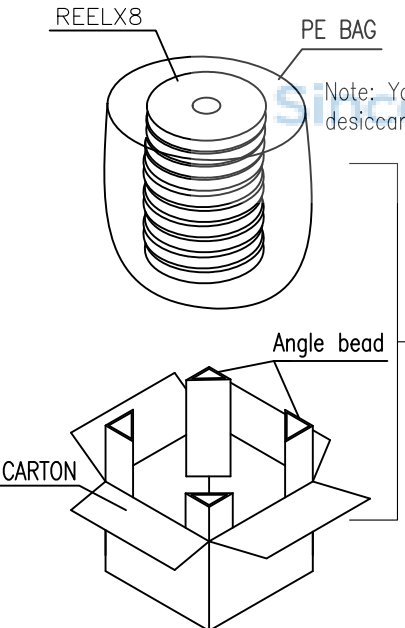

THIS DOCUMENT IS THE SOLE PROPERTY OF BBJconn Technology Co.,Ltd. Corporation AND SHOULD NOT BE USED IN WHOLE OR IN PART WITHOUT PRIOR WRITTEN PERMISSION.		深圳市步步精科技有限公司 工程管理部	
.X: ±0.38 .XX: ±0.25 .XXX: ±0.13		X': ±3" X'': ±2" .XX': ±1"	
APPD.	JM_Zheng	NAME: TYPE-C 24P 母座 直立式 H=10.0 四脚插 带柱 端子SMT (JAE) 不带LOGO 端子镀金15u (U23001-4)	
CHKD.	TSP	P.J. NO.: SIZE: A4 DRW NO.:	
PDWG.NO:	0382-1	FINISH: SEE NOTES MAT'L.: SEE NOTES	
DR.	LYX	SCALE: N/A REV.: AO UNIT: mm PAGE: 1/1	