

REV.	ECN NO.	CONTENT	DATE	ENGINEER
A0			2023 20/04	

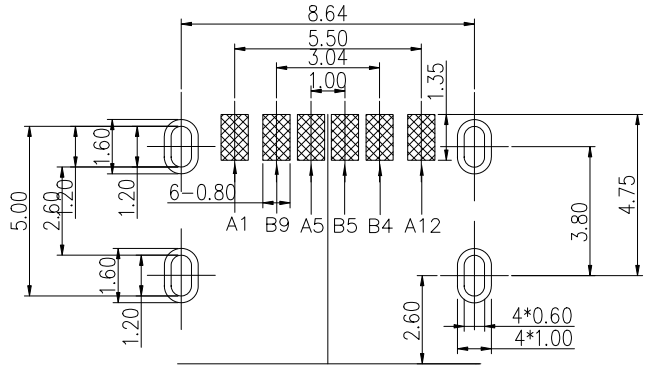

L	L = 7.4
---	---------

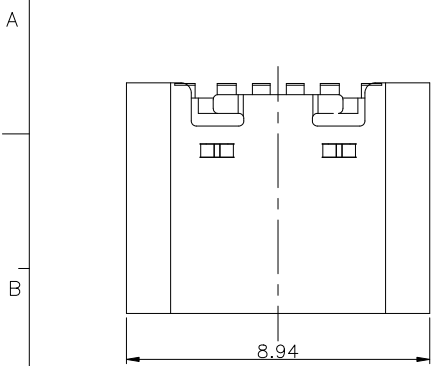

RECOMMENDED P.C.B. LAYOUT  
TOLERANCE UNSPECIFIED ±0.05mm

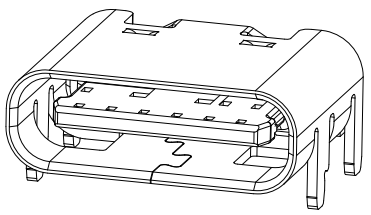
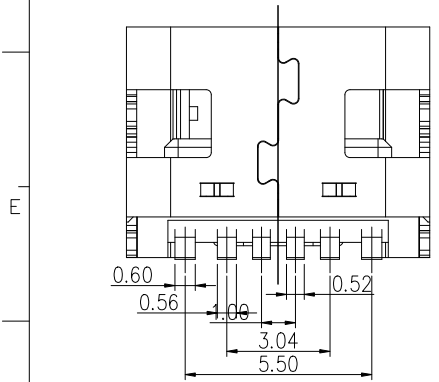
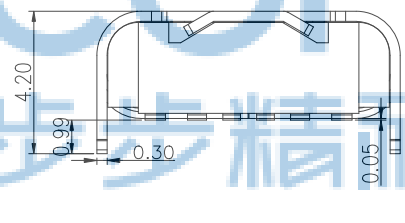
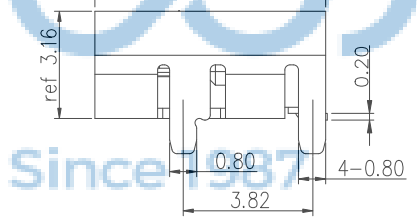
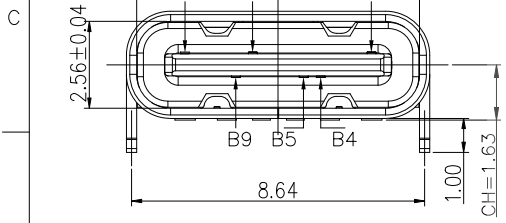

- NOTE:
- MATERIAL SPECIFICATION:
    - HOUSING: HIGH TEMPERATURE RESISTANT PLASTIC, LCP UL94 V-0.
    - CONTACTS: COPPER ALLOY C2680
    - MID PLATE: STAINLESS STEEL SUS301
    - FRONT SHELL: STAINLESS STEEL SUS304
  - PLATING SPECIFICATION:
    - CONTACTS:
      - Ni 50u" MIN. UNDER PLATED OVER ALL.
      - Au PLATED ON THE FUNCTIONAL AREA OF CONTACT. (GOLD PLATING THICKNESS FOLLOW)
    - FRONT SHELL: SEE TABLE1.
    - SHIELD PLATE&EMI PLATE: CLEAR ONLY
  - MECHANICAL PERFORMANCE,
    - INSERTION FORCE: 0.5~2.0kgf.
    - REMOVAL FORCE: 0.8kgf~2.0kgf.
    - DURABILITY: 10000 CYCLES.
  - ELECTRICAL PERFORMANCE,
    - CURRENT RATING: 3.0A  
VOLTAGE RATING: 5.0V
    - LLCR:
      - VBUS & GND PINS AND OTHER PINS: 40m"/PIN MAX.
      - SHIELD: 50m"/MAX.
      - LLCR MAX. CHANGE OF ALL PINS: 10m".
    - INSULATION RESISTANCE: 100M" MIN
    - DIELECTRIC WITHSTAND VOLTAGE, AC 100V FOR 1 MINUTE.
  - ENVIRONMENTAL PERFORMANCE:
    - OPERATING TEMPERATURE: -25°C~+85°C.
    - IR REFLOW: THE PEAK TEMPERATURE ON THE BOARD SHALL BE MAINTAINED FOR 10 SECONDS AT 260°C.

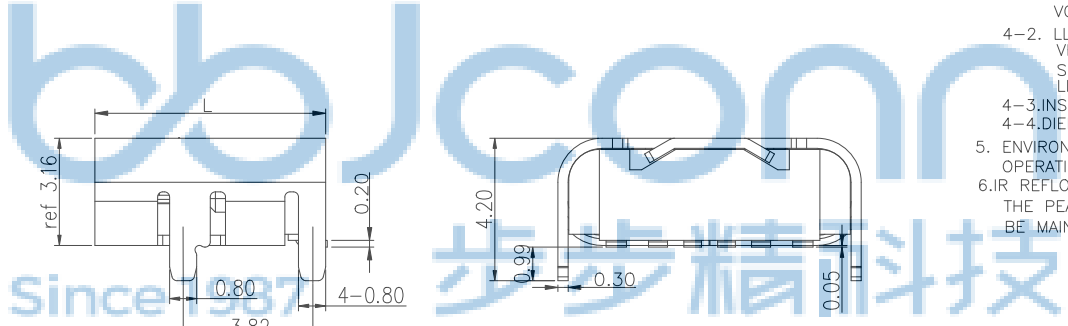

PIN ASSIGNMENTS

A1	GND	B9	VBUS
A5	CC1	B5	CC2
A12	GND	B4	VBUS
PIN	SIGNAL NAME	PIN	SIGNAL NAME

THIS DOCUMENT IS THE SOLE PROPERTY OF BBJconn Technology Co.,Ltd. CORPORATION AND SHOULD NOT BE USED IN WHOLE OR IN PART WITHOUT PRIOR WRITTEN PERMISSION. PDWG.NO:XX **0325-2**

**深圳市步步精科技有限公司**

.X: ±0.38 X': ±3"  
.XX: ±0.25 .X': ±2"  
.XXX: ±0.13 .XX': ±1"

NAME: TYPE-C 6P 母座 板上四脚插 L=7.40  
CH=1.63 端子SMT 带中夹片 编带

APPD. JM\_Zheng 23/05'02

CHKD. TSP 23/05'02

DR. LYX 23/05'02

PJ. NO.: 126-221-060011-S8G  
SIZE: A4 DRW NO.:

FINISH: SEE NOTES MAT'L.: SEE NOTES  
SCALE: N/A REV.: A3 UNIT: mm PAGE: 1/1

REV.	ECN NO.	CONTENT	DATE	ENGINEER
A0			2023 20/04	

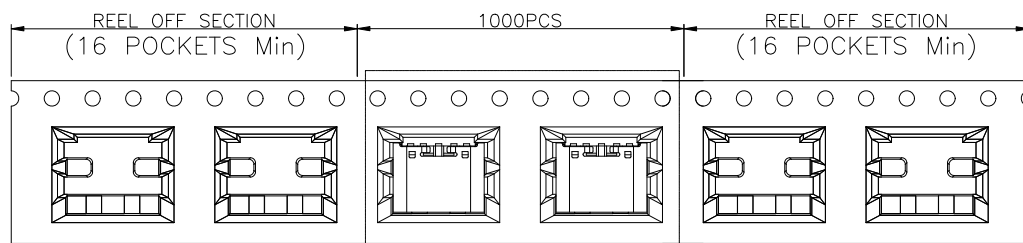

SEE DETAIL X

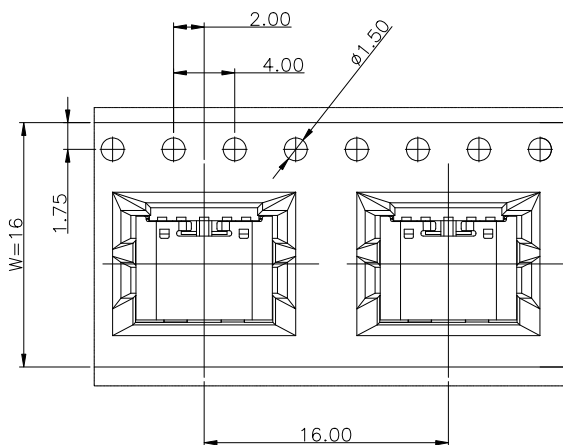
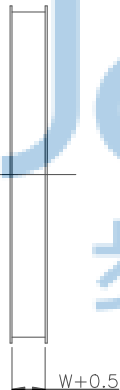
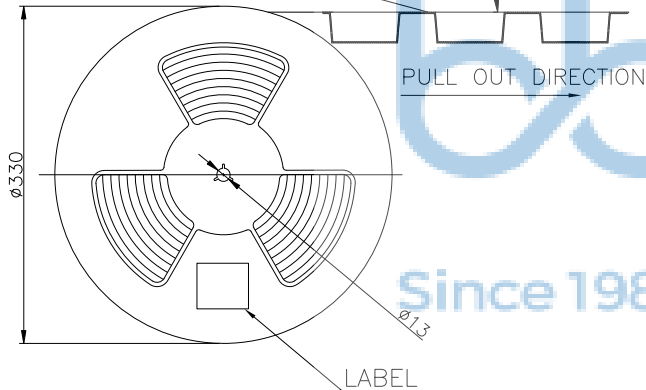

REEL OFF DIRECTION

PULL OUT DIRECTION

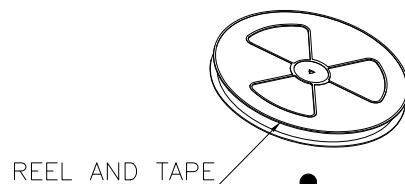

REEL AND TAPE

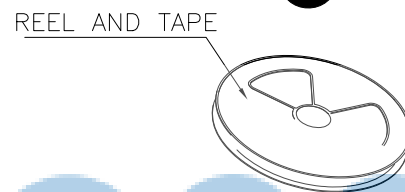

REEL AND TAPE

TAPE & REEL 15 PCS  
1 REEL = 1000 PCS

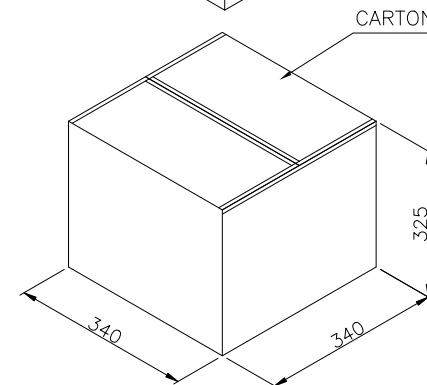
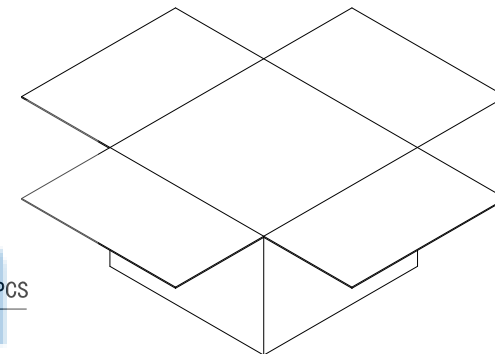
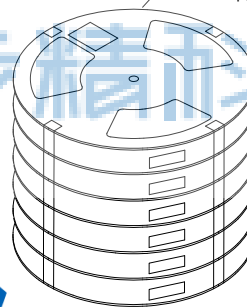

	REEL	CARTON
CONNECTOR (PCS)	1000	10000

THIS DOCUMENT IS THE SOLE PROPERTY OF BBJconn Technology Co.,Ltd. Corporation AND SHOULD NOT BE USED IN WHOLE OR IN PART WITHOUT PRIOR WRITTEN PERMISSION. PDWG.NO:XX <b>0325-2</b>		<b>深圳市步步精科技有限公司</b> .X: ±0.38 .X': ±3" .XX: ±0.25 .X': ±2" .XXX: ±0.13 .XX': ±1"		NAME: TYPE-C 6P 母座 板上四脚插 L=7.40 CH=1.63 端子SMT 带中夹片 带带 APPD. JM_Zheng 23/05'02 CHKD. TSP 23/05'02 DR. LYX 23/05'02	
		PJ. NO.: 126-221-060011-S8G SIZE: A4 DRW NO.:		FINISH: SEE NOTES MAT'L.: SEE NOTES SCALE: N/A REV.: A3 UNIT: mm PAGE: 1/1	