

REV.	ECN NO	CONTENT	DATE	ENGINEER
A0		Initial release	/	TSP

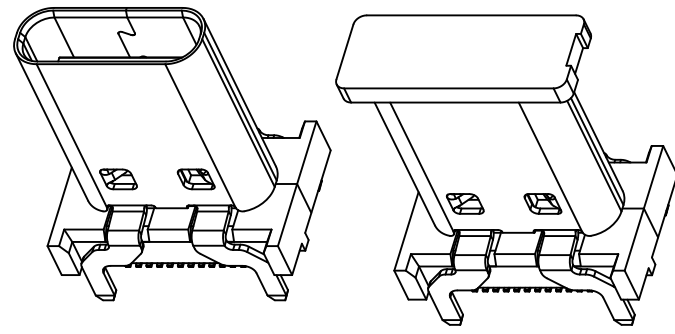

- Contact Resistance: 40mOHM Max.;
- Dielectric Withstanding Voltage: 100V AC For 1 Minute;
- Insulation Resistance: 100M OHM Min.;
- Mating And Unmating Force:
Mating Force: 5~20N
Unmating Force: 8~20N;
6~20N AFTER TEST;
- Durability: 10000 Cycles;

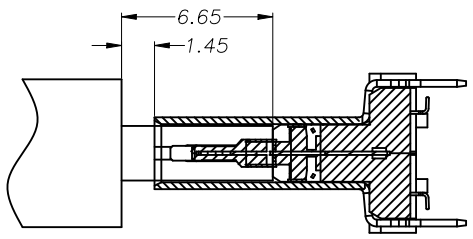
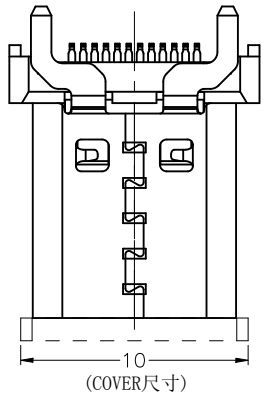
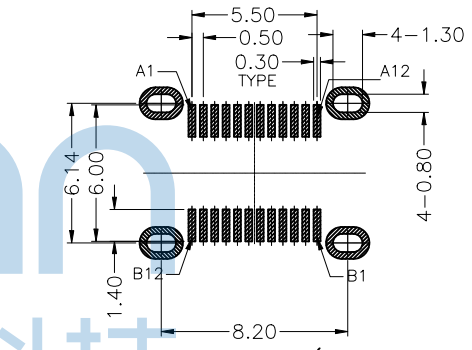
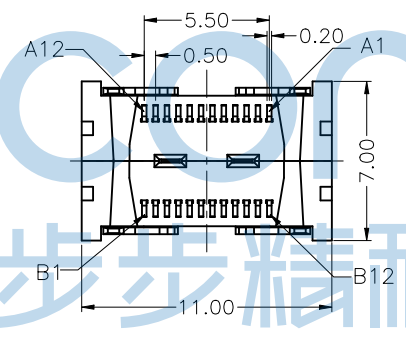
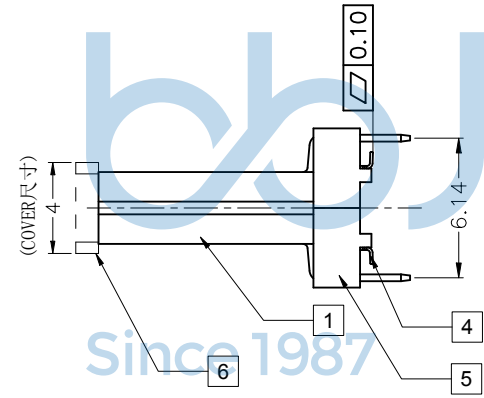
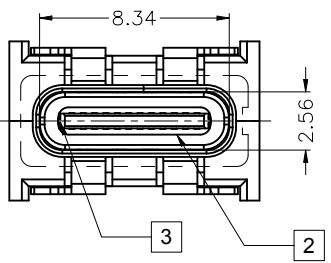

RECOMMEND P.C.B LAYOUT (COMPONENT SIDE)
TOLERANCE FOR PCB LAYOUT IS ± 0.05
KEEP OUT AREA

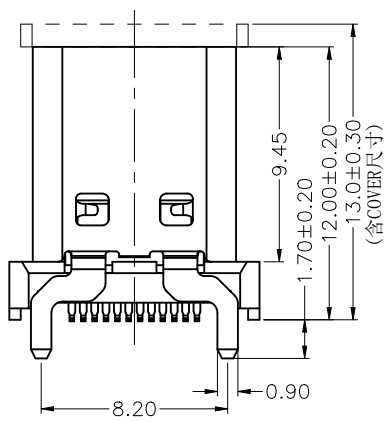

USB TYPE-C PIN ASSIGNMENTS

PIN NUMBER	SIGNAL NAME	PIN NUMBER	SIGNAL NAME
A1	GND	B12	GND
A2	TX1+	B11	RX1+
A3	TX1-	B10	RX1-
A4	VBUS	B9	Vbus
A5	CC1	B8	SBU2
A6	D+	B7	D-
A7	D-	B6	D+
A8	SBU1	B5	CC2
A9	VBUS	B4	Vbus
A10	RX2-	B3	TX2-
A11	RX2+	B2	TX2+
A12	GND	B1	GND

Item	Title	Material	Dispose	Q'TY
1	Shell	Stainless Steel	Ni:30u" Min.	1PCS
2	GND Plate	Stainless Steel		2PCS
3	Mid Plate	Stainless Steel		1PCS
4	Contact	Copper Alloy	Mating Area: Au 1u" Solder Tails: Matt Tin	24PCS
5	InsertMolding	High Temperature Plastic	UL 94V-0 Black	1PCS
6	COVER	High Temperature Plastic	UL 94V-0 Black	1PCS

THIS DOCUMENT IS THE SOLE PROPERTY OF BBJconn Technology Co.,Ltd. Corporation AND SHOULD NOT BE USED IN WHOLE OR IN PART WITHOUT PRIOR WRITTEN PERMISSION.

PDWG.NO: 0470-1

深圳市步步精科技有限公司

NAME: USB 3.1 TYPE-C 24P 母座 直立式
四脚插 端子SMT H=12.0 编带

APPD. JM_Zheng
CHKD. LYX
DR. TSP

PJ. NO.: 126-226-240003-U4G
SIZE: A4 | DRW NO.:
FINISH: SEE NOTES | MAT'L.: SEE NOTES
SCALE: N/A | REV.: A0 | UNIT: mm | PAGE: 1/2

REV.	ECN NO	CONTENT	DATE	ENGINEER
A0		Initial release	/	TSP

产品规格 Product spec.	个/卷 Pcs/Reel	250
包装容量 卷/箱 Reel/Ctos.	卷/箱 Pcs/Ctos.	8
重量 Weigh (Kg)	净重 N. W.	/kg
	毛重 G. W.	/kg

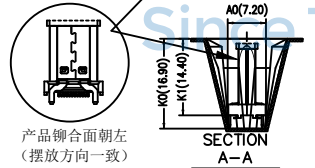
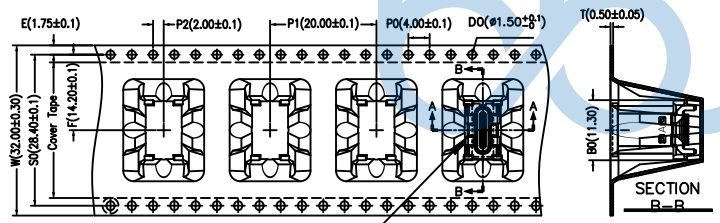
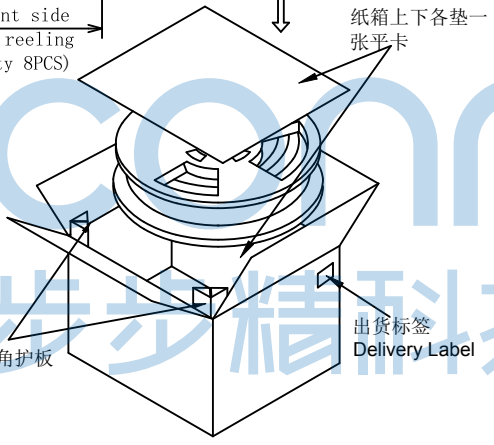
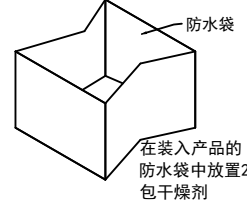
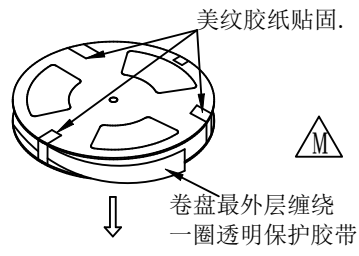
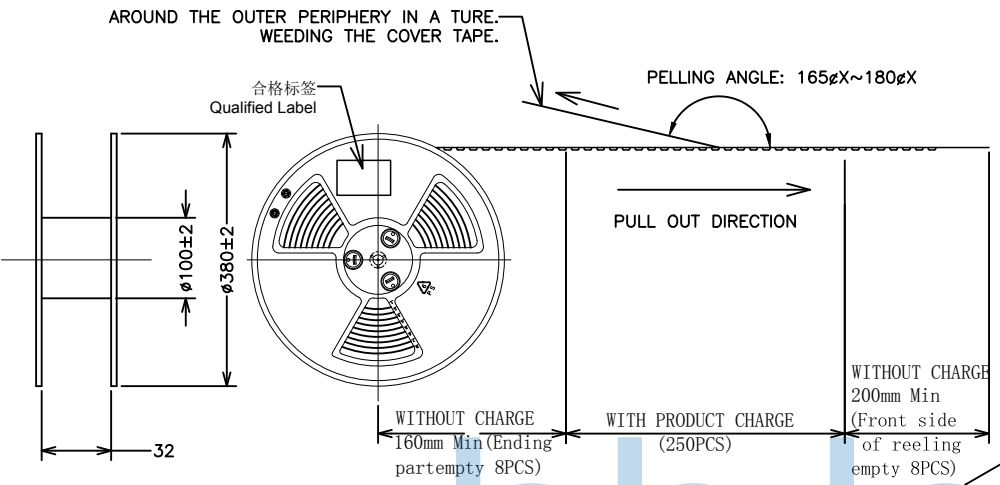

包装规范说明:

1. 如图所示首先CARRIER TAPE (载带) 需先预留8PCS空格后方可置入成品,并附COVER TPAE(上带)覆盖于上,再配合带装机自动卷绕于REEL(塑胶卷轴)收料。
As shown from picture, the initial starting carrier need to be emptied for 8 pcs, then put connector on Inth carrier; Then cover it with Cover Tape, and Reeling it with Reel auto machine.
2. 在定量包装完成后,前端CARRIER TAPE 亦需预留8PCS空格,而COVER TPAE 配合CARRIER TYPE 长度覆盖后,并须再超出200mm以上,最后以胶纸贴固,并于REEL盘上方贴好标签.最外圈缠绕一圈保护带。
In the end of the Reel, need to empty 8 pcs carrier tape; After covering the carrier, then the Cover Tape need to be 200mm longer, and use tape to fix the cover tape to the reel. Put ualified Label on the tape. The outermost ring is wound around a protective band.
3. 注意:COVER TAPE 不可浮起或有贴附不顺,歪斜及成品放置方向错误的现象。
Attention: no deformation of Cover Tape is allowed (protruded plastic, or not smooth, bednt or product is wrong positioned)
4. 在纸箱内左右,前后侧各放入一块三角卡板,每个PE袋中装入8个REEL盘,并在PE袋中放入2PCS干燥剂,用胶带封好,在纸箱内上下各垫一张平卡, 每个纸箱内装入8PCS卷盘,共1叠.盖上箱盖后以胶带封箱,于图示位置贴好标签.Inside of carton, at left and right side, put triangle fixed card; Put8Reels to PE bag, and put 1 bags of desiccant inside the PE bag. Each carton has 8 reels. Put "Delivery label" on side of the carton.
5. 零箱部分, 出货时须用缓冲物填满。
The fractional box must be filled by cushion before shipment.



NO.	包材名称 Items	用量 Usage	适用类别 Series	备注 / Remark
①	纸箱 Carton	1	广东省外,K=K	400*400*310mm
②	PE Bag	2		600*600*0.05mm
③	carrier tape	8		W=32mm PET 透明L=5.32M
④	cover tape	/		W=25.5MM,200m/r透明色
⑤	塑胶卷轴 Plastic Reel	8		Ø380mm,W=37mm
⑥	干燥剂 Desiccant	4		
⑦	出货标签 Delivery Label	1		80*60mm
⑧	保护带 Protect tape	1		W32*400M/R

THIS DOCUMENT IS THE SOLE PROPERTY OF BBJconn Technology Co.,Ltd. Corporation AND SHOULD NOT BE USED IN WHOLE OR IN PART WITHOUT PRIOR WRITTEN PERMISSION.
PDWG:NO: 0470-1

深圳市步步精科技有限公司

NAME: USB 3.1 TYPE-C 24P 母座 直立式 四脚插 端子SMT H=12.0 编带

PJ. NO.: 126-226-240003-U4G
SIZE: A4 DRW NO.:

FINISH: SEE NOTES MAT'L.: SEE NOTES
SCALE: N/A REV.: A0 UNIT: mm PAGE: 2/2

APPD. JM_Zheng
CHKD. LYX
DR. TSP