



REV	ECN NO	CONTENT	DATE	ENGINEER
A0		INITIAL RELEASE	/	SGF

备注:

1. 材质:

1.1 胶芯: PA9T, UL94V-0; 黑色.

1.2 端子: 高导电C7025, T=0.12mm; 接触区镍底300"Min 镀金1-300"; 焊脚镍底300" Min, 镀金G/F

1.3 外壳: SUS304 T=0.25mm, 镀镍300"Min.

1.4 中夹片: SUS301 T=0.12MM 镀镍300".

2. 主要特性:

2.1 额定电流: 5A

2.2 接触阻抗: 40mΩ MAX (初始值)
50mΩ MAX (测试后)

2.3 绝缘阻抗: 100M Ω MIN

2.4 耐压测试 100V AC R. M. S.

2.5 整体插入力: 5-20N 整体插入力: 5-20N (耐久后)
整体拔出力: 8-20N 整体拔出力: 6-20N (耐久后)

2.6 耐久: 10000 次

2.7 耐高温: SMT 回流焊 (峰值260° ±5°), 塑胶不能有起泡, 融胶等不良变色, 翘曲变形在公差范围以内

2.8 产品须做焊锡测试 沾锡面积达到95%以上;

2.9 盐雾测试: 48H MIN

3.0 工作温度: -30 °C ~ +85 °C

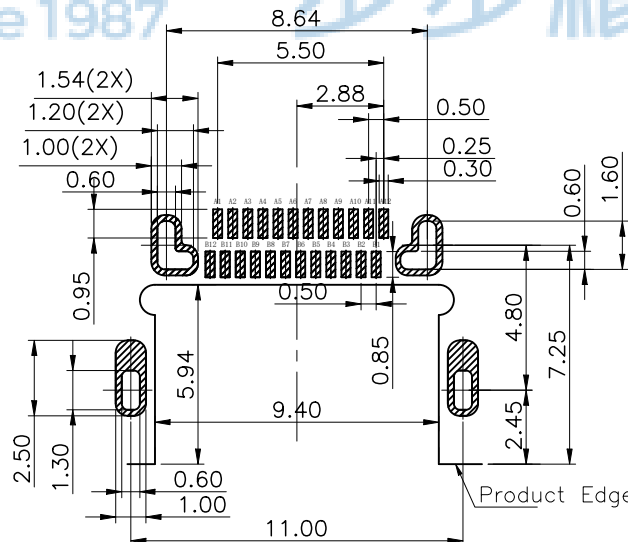
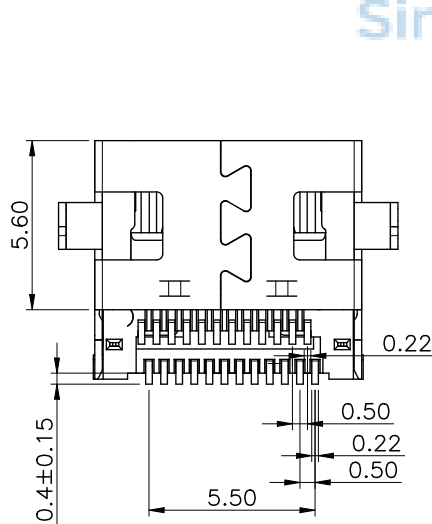
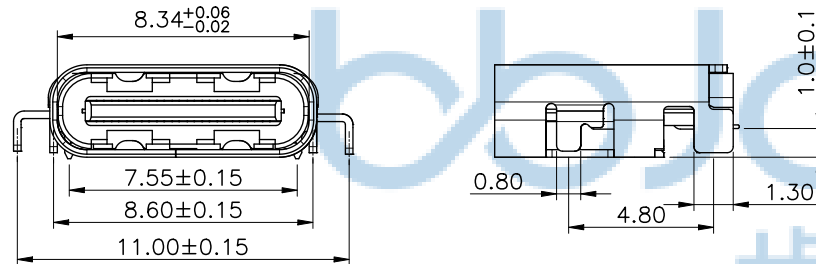
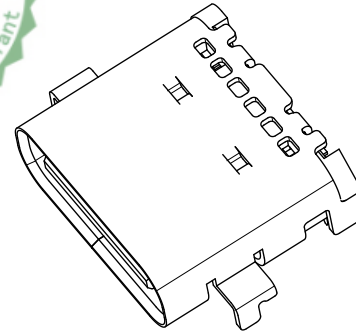
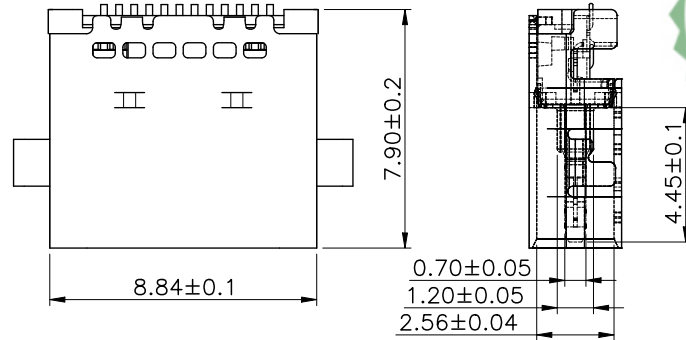

RECOMMENDED PCB LAYOUT(TOP VIEW)



PIN NUMBER	SIGNAL NAME	PIN NUMBER	SIGNAL NAME
A1	GND	B12	GND
A2	SSTXp1	B11	SSRXp1
A3	SSTXn1	B10	SSRXn1
A4	VBUS	B9	VBUS
A5	CC1	B8	SBU2
A6	Dp1	B7	Dn2
A7	Dn1	B6	Dp2
A8	SBU1	B5	CC2
A9	VBUS	B4	VBUS
A10	SSRXn2	B3	SSTXn2
A11	SSRXp2	B2	SSTXp2
A12	GND	B1	GND

THIS DOCUMENT IS THE
SOLE PROPERTY OF

BBJconn Technology Co., Ltd.
Corporation AND SHOULD

NOT BE USED IN WHOLE
PRIOR WRITTEN PERMISSION.

PDWG NO: 0470-1

深圳市步步精科技有限公司

.X: ±0.38 X': ±3"
.XX: ±0.25 .X': ±2"
.XXX: ±0.13 .XX': ±1"

NAME: TYPE-C 24P 母座 无后盖 四脚插 端子
双排SMT 沉板1.0 L=7.9 编带

APPD JM_Zheng
CHKD LYX

PJ NO: 126-221-240021-U4G
SIZE:A4 DRW NO:

DR SGF

FINISH:SEE NOTES MAT'L:SEE NOTES
SCALE:N/A REV:A0 UNIT:mm PAGE:1/2

REV	ECN NO	CONTENT	DATE	ENGINEER
AO		INITIAL RELEASE	/	SGF

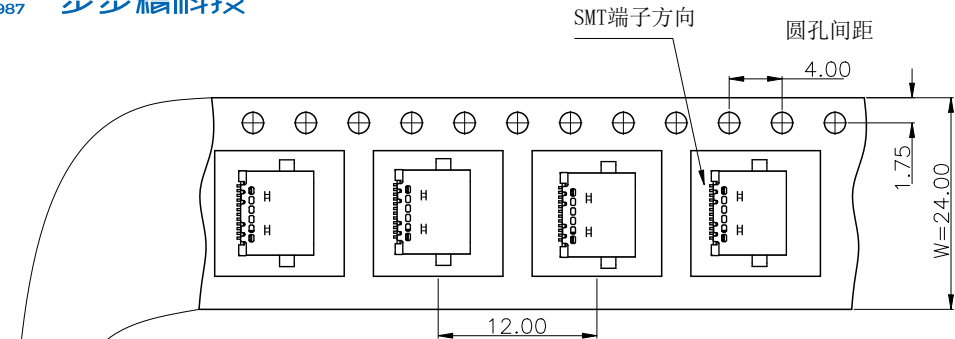

包装示意图:

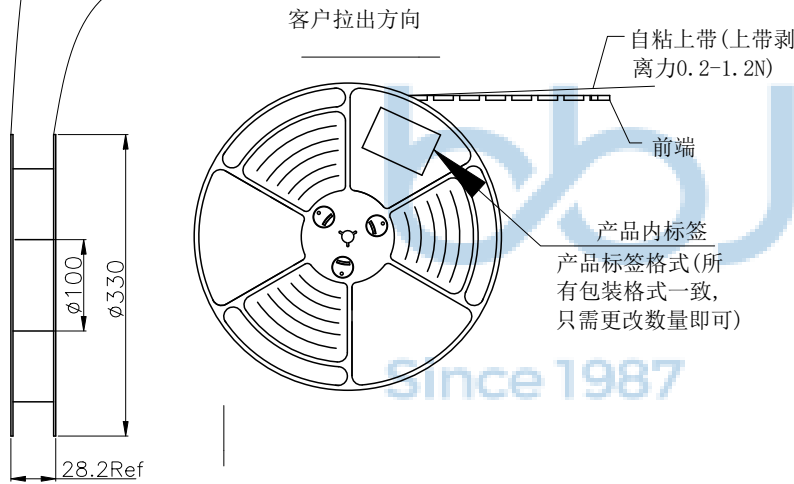
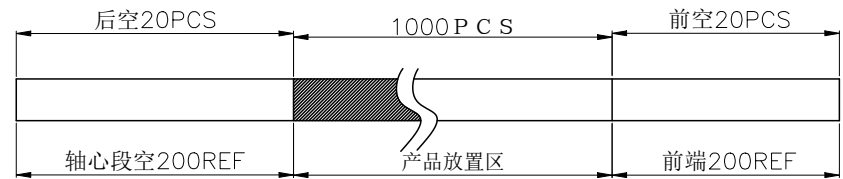

产品外标签

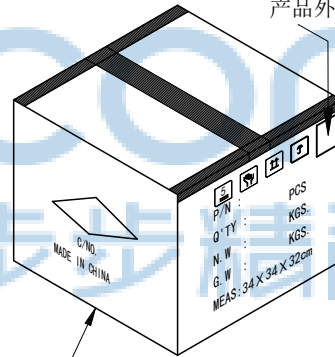

备注:

1. 把下载带送入载带机进行调整, 然后将产品按照指定的方式摆入下载带中, 开动卷带机进行卷装 (每卷包1000PCS), 卷装完成后需用上带缠绕最少20CM;
2. 在卷装OK的每卷盘面的指定位置上贴上物料和RoHS 标签装入纸箱内; 每箱装10盘, 共计10000PCS.
3. 纸箱用封箱带将其封好, 胶带要求工字型, 不可遮住标签;
4. 如果客户对包装标签另有要求, 请按客户要求作业; 有未满之零数箱需用缓冲材料填充;
5. 上载带剥离力: 0.2-1.2N. ;

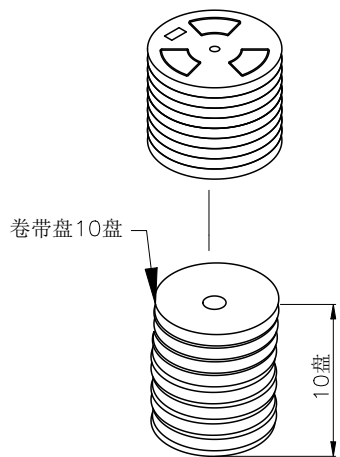

将10盘产品放入纸箱内

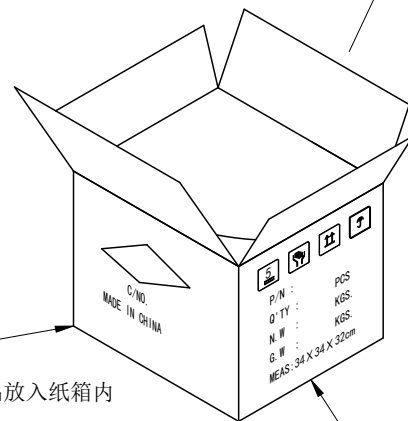

纸箱规格:
34.0X34.0X32CM



THIS DOCUMENT IS THE SOLE PROPERTY OF BBJconn Technology Co.,Ltd. Corporation AND SHOULD NOT BE USED IN WHOLE PRIOR WRITTEN PERMISSION.	深圳市步步精科技有限公司		NAME: TYPE-C 24P 母座 无后盖 四脚插 端子 双排SMT 沉板1.0 L=7.9 编带		
	.X: ±0.38 .XX: ±0.25 .XXX: ±0.13	X': ±3' .X': ±2' .XX': ±1'	APPD	JM_Zheng	PJ NO: 126-221-240021-U4G
PDWG NO: 0470-1	DR	SGF	CHKD	LYX	SIZE:A4 DRW NO:
					FINISH:SEE NOTES MAT'L:SEE NOTES
					SCALE:N/A REV:AO UNIT:mm PAGE:2/2