

REV	ECN NO	CONTENT	DATE	ENGINEER
A0		INITIAL RELEASE	/	SGF

SPECIFICATION:

1.ELECTRICAL CHARACTERISTICS:

- 1.1 CURRENT RATING: 5A
- 1.2 TEMPERATURE RANGE: -40 °C ~ 85 °C
- 1.3 CONTACT RESISTANCE: 30 MILLIONHM MAX.
- 1.4 DIELECTRIC WITHSTANDING VOLTAGE: 100 VAC r.m.s
- 1.5 INSULATION RESISTNACE: 100 MEGOHMS MIN.

2.MECHANICAL CHARACTERISTICS

- 2.1 INSERTION FORCE: 5~20N
- 2.2 EXTRACTION FORCE: Initial:8~20N,ATER TEST 6~20N
- 2.3 DURABILITY:10,000CYCLES

3.THE SHELL LENTH IS LESS THAN THE MINIMUM SPECIFIED BY THE USB TYPE C STANDARD.AS SUCH IS CANNOT INDENOENDENTLY BE GUARANTEED TO MEET ALL TYPE C MECHANICAL REQUIREMENTS.

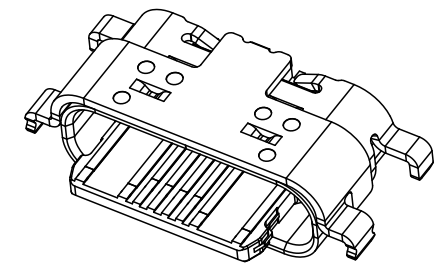
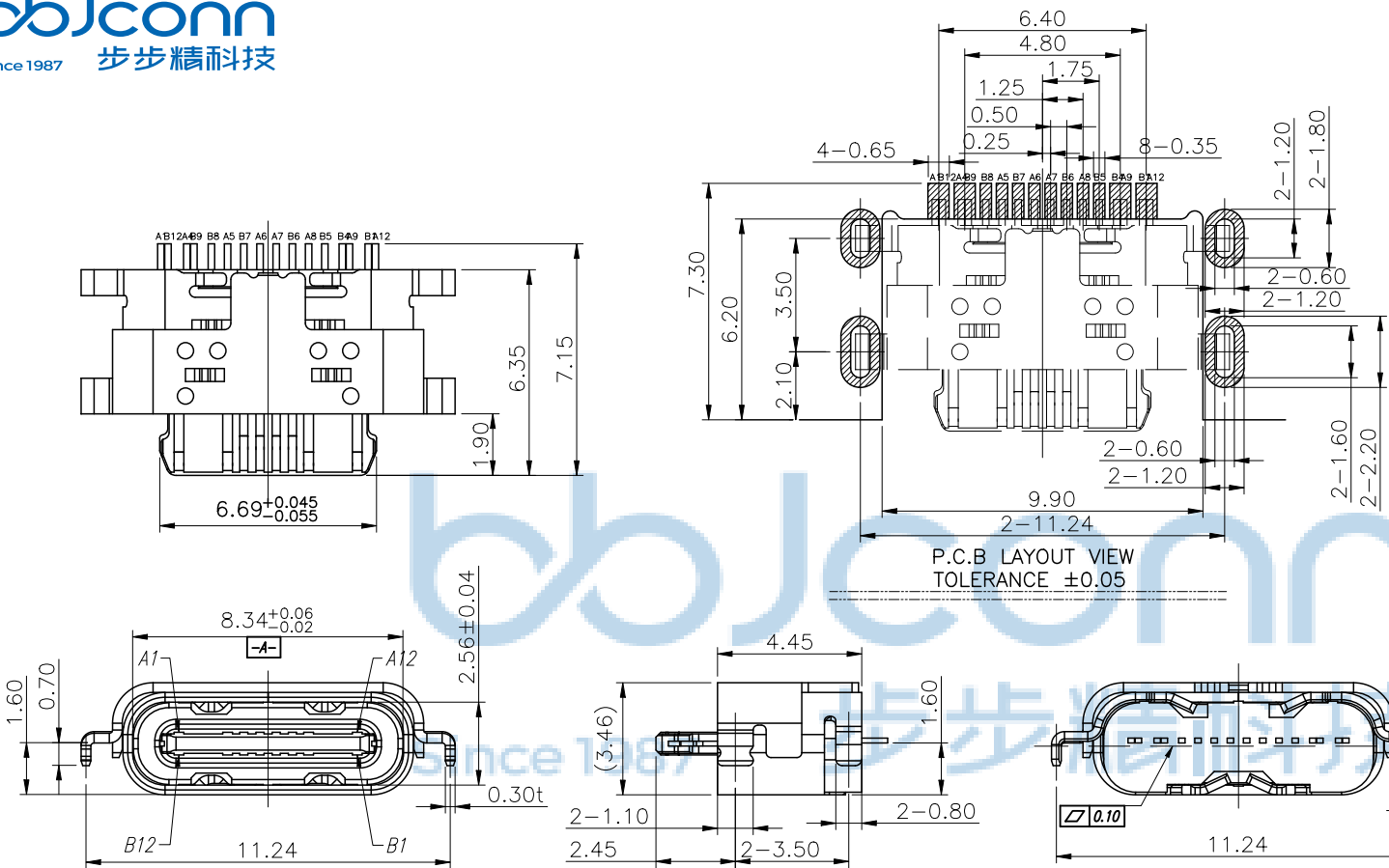

NO.	DESCRIPTION	QTY.	MATERIAL	FINISHED
4	MID PLATE	1 PCS	SUS301	None
3	CONTACT	1 SET	C7025	Au & Ni Plated
2	MOLDING HOUSING	1 PCS	PA46	None
1	SHELL	1 PCS	SUS304	Ni Plated

**深圳市步步精科技有限公司**

THIS DOCUMENT IS THE SOLE PROPERTY OF BBJconn Technology Co.,Ltd. Corporation AND SHOULD NOT BE USED IN WHOLE PRIOR WRITTEN PERMISSION.

NAME: TYPE-C 16P 母座 四脚插 沉板1.6 舌片外漏1.9 端子SMT L=4.45 带中夹片 编带	
APPD: JM_Zheng	PJ NO: 126-221-160038-M3G
CHKD: LYX	SIZE:A4   DRW NO:
FINISH:SEE NOTES	MAT'L:SEE NOTES
SCALE:N/A	REV:A0   UNIT:mm   PAGE:1/2

PIN ASSIGNMENT												BLADE	SHELL
A1	A2	A3	A4	A5	A6	A7	A8	A9	A10	A11	A12		
GND	TX1+	TX1-	VBUS	CC1	D+	D-	SBU1	VBUS	RX2-	RX2+	GND		
GND	RX1+	RX1-	VBUS	SBU2	D+	D-	CC2	VBUS	TX2-	TX2+	GND	GND	GND
B12	B11	B10	B9	B8	B7	B6	B5	B4	B3	B2	B1		

PDWG NO: 0851-1

DR SGF

REV	ECN NO	CONTENT	DATE	ENGINEER
AO		INITIAL RELEASE	/	SGF

160mmMIN.(15CAV. EMPTY)      LOADING 1500 PCS      300mmMIN.(20CAV. EMPTY)      100mmMIN.

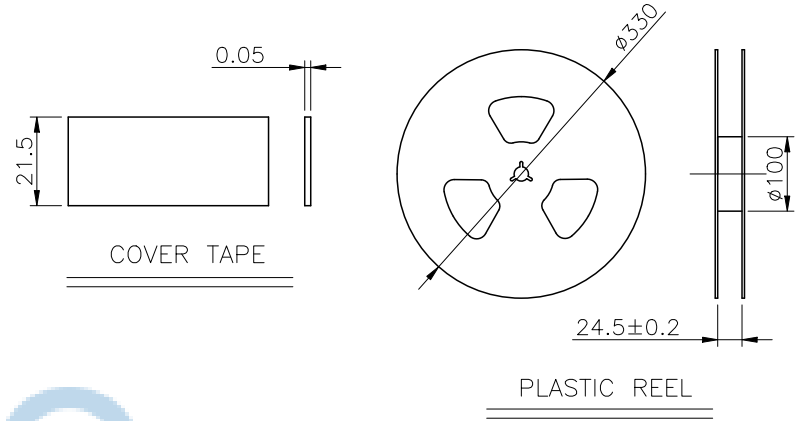
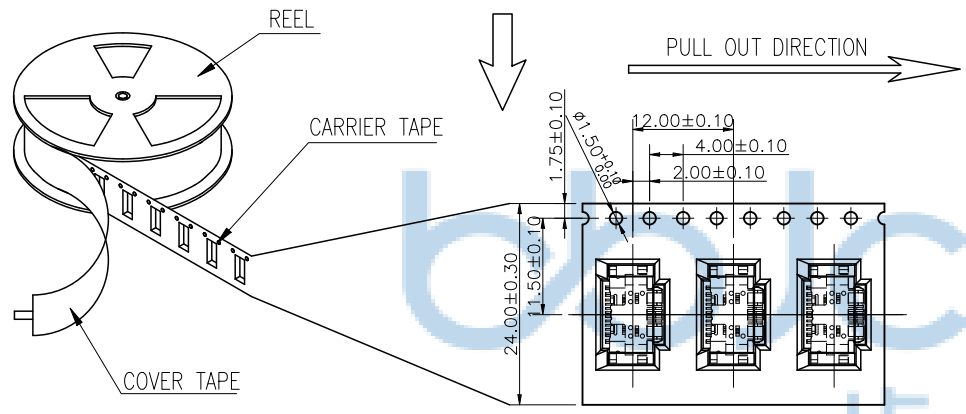
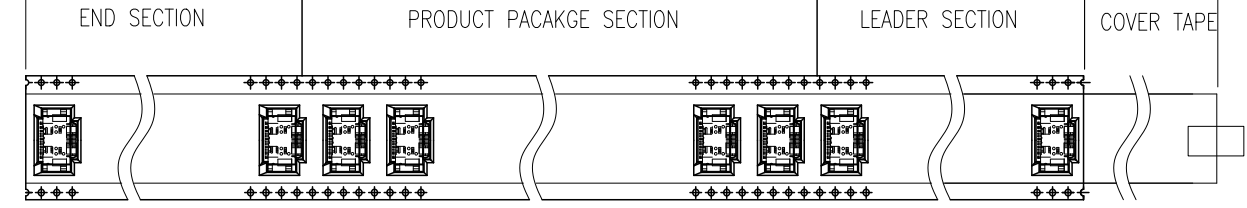

- NOTES 2:
- MATERIAL:
    - 1.1 REEL AND AXLE: PS,BLUE
    - 1.2 CARRIER TAPE: PET, LUCID
    - 1.3 COVER TAPE: PS,TRANSPARENT
    - 1.4 SHIPPING CARTON: CORRUGATED FIBER
  - DIMENSION:
    - 2.1 REEL: W=24.5, φA=330
    - 2.2 CARRIER TAPE: T=0.30 W=24.0
    - 2.3 COVER TAPE: T=0.05 W=21.5
    - 2.4 SHIPPING CARTON: L=335mm, W=335mm, H=365mm
  - QUANTITY :
    - 3.1 PRIMAY PACKING: 1500 PCS/REEL
    - 3.2 SECONARY PACKING: 12 REELS/CARTON(1800 PCS/CARTON)
  - PEELING RESISTANCE: 0.1~1.3N
    - 4.1 PEELING SPEED: 300mm/minutes
    - 4.2 PEELING ANGLE: 165° ~180°

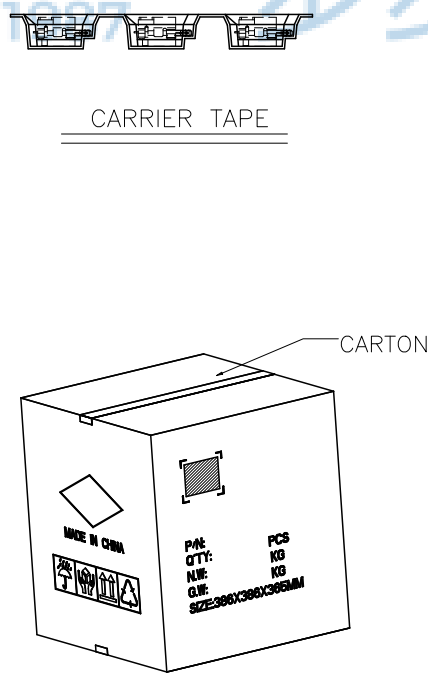
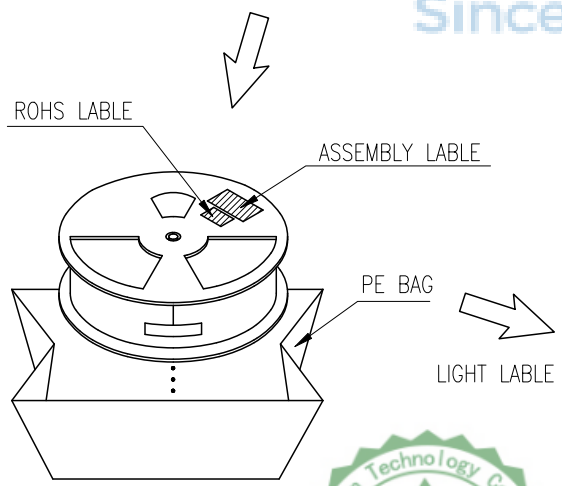

THIS DOCUMENT IS THE SOLE PROPERTY OF BBJconn Technology Co.,Ltd. Corporation AND SHOULD NOT BE USED IN WHOLE PRIOR WRITTEN PERMISSION.		深圳市步步精科技有限公司 工程部 APPROVED	
PDWG NO: 0851-1	DR	SGF	NAME: TYPE-C 16P 母座 四脚插 沉板1.6 舌片外漏1.9 端子SMT L=4.45 带中夹片 编带 PJ NO: 126-221-160038-M3G SIZE:A4   DRW NO: FINISH:SEE NOTES   MAT'L:SEE NOTES SCALE:N/A   REV:AO   UNIT:mm   PAGE:2/2