

REV	ECN NO	CONTENT	DATE	ENGINEER
A0		INITIAL RELEASE	/	SGF

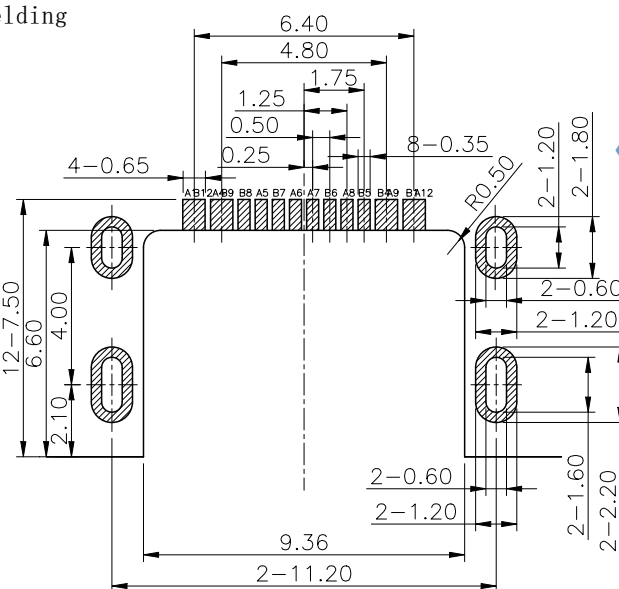

SPECIFICATION:

- ELECTRICAL CHARACTERISTICS:
  - CURRENT RATING: 5A
  - TEMPERATURE RANGE: -40 °C ~ 85 °C
  - CONTACT RESISTANCE: 30 MILLIONHM MAX.
  - DIELECTRIC WITHSTANDING VOLTAGE: 100 VAC r.m.s
  - INSULATION RESISTNACE: 100 MEGOHMS MIN.
- MECHANICAL CHARACTERISTICS
  - INSERTION FORCE: 5~20N
  - EXTRACTION FORCE: Initial:8~20N,ATER TEST 6~20N
  - DURABILITY:10,000CYCLES
- THE SHELL LENTH IS LESS THAN THE MINIMUM SPECIFIED BY THE USB TYPE C STANDARD.AS SUCH IS CONNOT INDOENOENTLY BE GUARANTEED TO MEET ALL TYPE C MECHANICAL REQUIREMENTS.

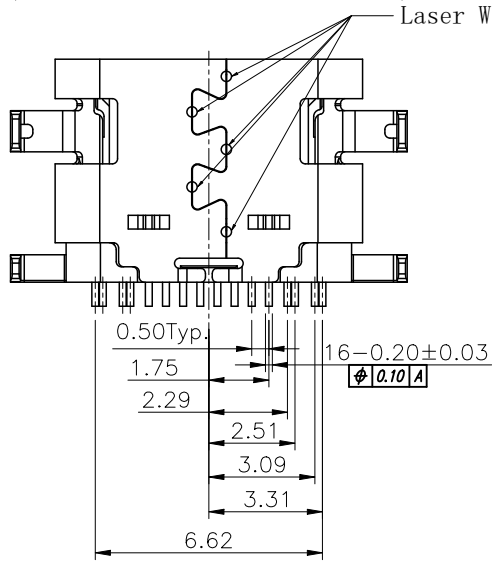
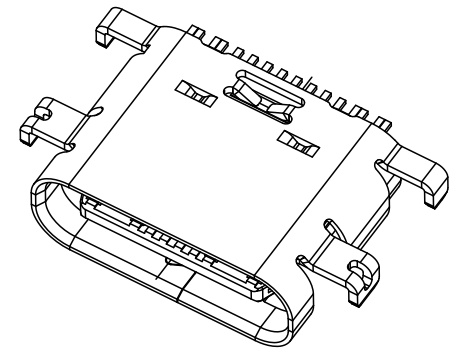
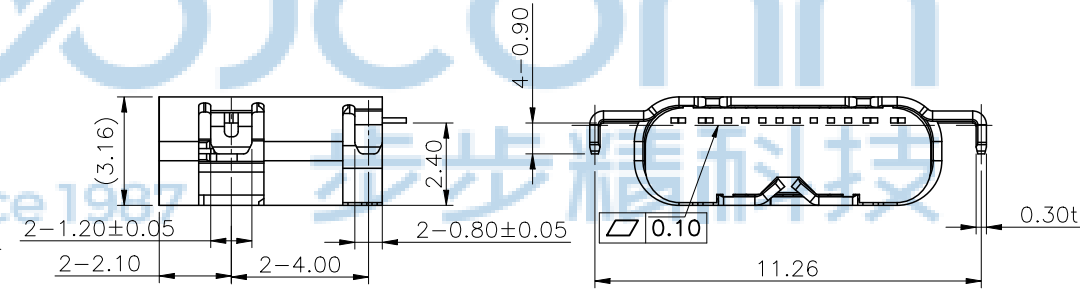
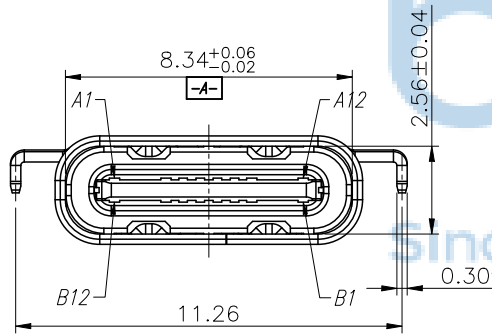
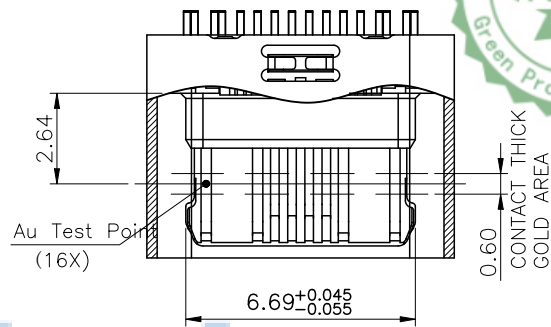
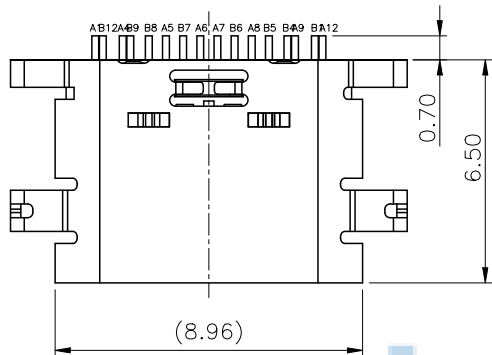

PIN ASSIGNMENT												BLADE	SHELL
A1	A2	A3	A4	A5	A6	A7	A8	A9	A10	A11	A12		
GND	TX1+	TX1-	VBUS	CC1	D+	D-	SBU1	VBUS	RX2-	RX2+	GND		
GND	RX1+	RX1-	VBUS	SBU2	D-	D+	CC2	VBUS	TX2-	TX2+	GND	GND	GND
B12	B11	B10	B9	B8	B7	B6	B5	B4	B3	B2	B1		

NO.	DESCRIPTION	QTY.	MATERIAL	FINISHED
4	MID PLATE	1 PCS	SUS301	None
3	CONTACT	1 SET	C7025	Au & Ni Plated
2	MOLDING	1 PCS	PA46	None
1	HOUSING SHELL	1 PCS	SUS304	Ni Plated

THIS DOCUMENT IS THE SOLE PROPERTY OF BBJconn Technology Co.,Ltd. Corporation AND SHOULD NOT BE USED IN WHOLE PRIOR WRITTEN PERMISSION. PDWG NO: 0851-1

**深圳市步步精科技有限公司**

NAME: TYPE-C 16P 母座 90度 沉板2.40 四脚插 端子SMT L=6.50 带中夹片 编带 战斗版

APPD: JM\_Zheng  
CHKD: LYX  
DR: SGF

PJ NO: 126-221-160039-M3G  
SIZE:A4  
FINISH:SEE NOTES  
SCALE:N/A

MAT'L:SEE NOTES  
DRW NO:  
REV:A0  
UNIT:mm  
PAGE:1/2

REV	ECN NO	CONTENT	DATE	ENGINEER
AO		INITIAL RELEASE	/	SGF

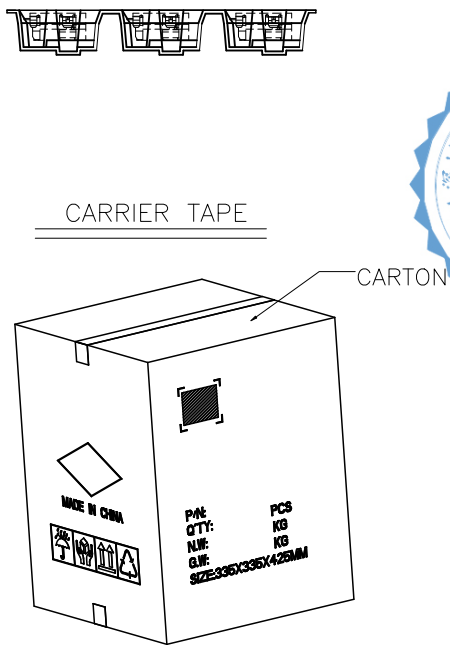
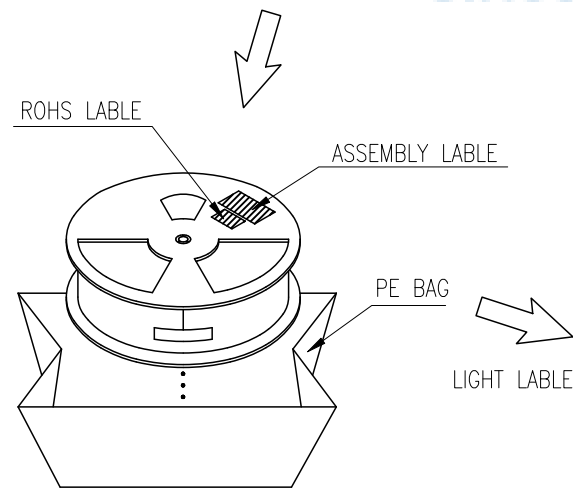
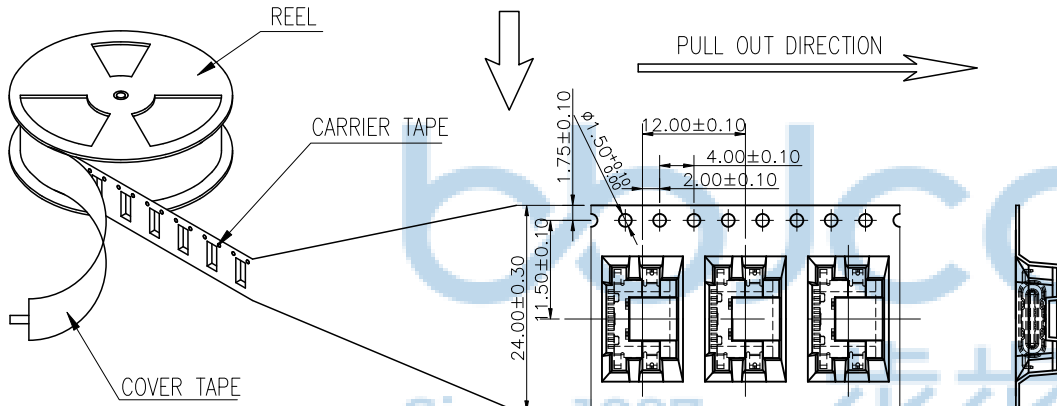
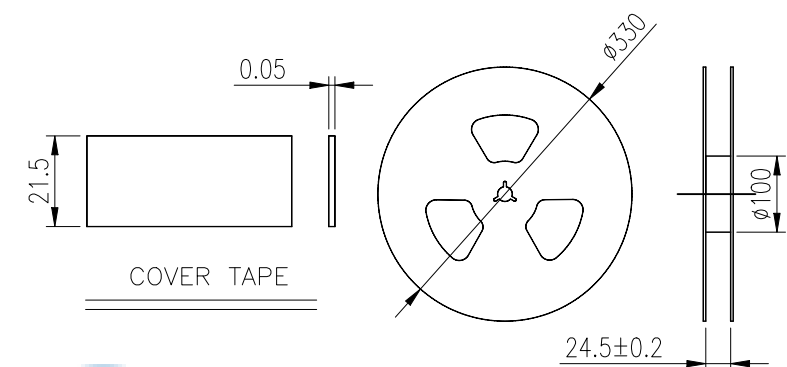
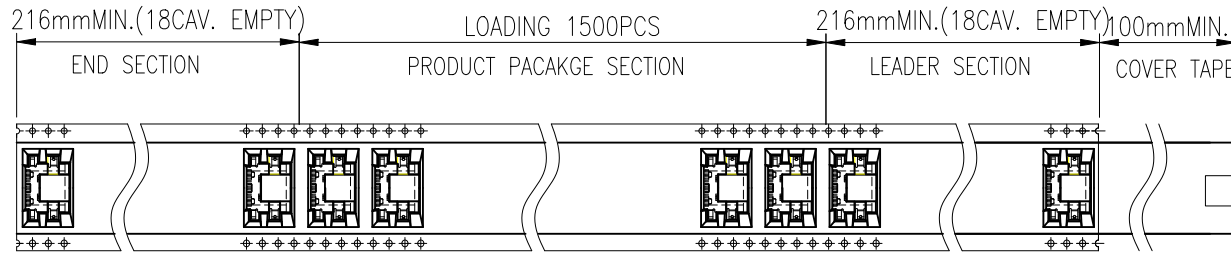

- NOTES 2:
- MATERIAL:
    - 1.1 REEL AND AXLE: PS,BLUE
    - 1.2 CARRIER TAPE: PET, LUCID
    - 1.3 COVER TAPE: PS,TRANSPARENT
    - 1.4 SHIPPING CARTON: CORRUGATED FIBER
  - DIMENSION:
    - 2.1 REEL: W=24.5,  $\phi A=330$
    - 2.2 CARRIER TAPE: T=0.30 W=24.0
    - 2.3 COVER TAPE: T=0.05 W=21.5
    - 2.4 SHIPPING CARTON: L=335mm, W=335mm, H=425mm
  - QUANTITY :
    - 3.1 PRIMAY PACKING: 1500PCS/REEL
    - 3.2 SECONARY PACKING: 12 REELS/CARTON(18000PCS/CARTON)
  - PEELING RESISTANCE: 0.1~1.3N
    - 4.1 PEELING SPEED: 300mm/minutes
    - 4.2 PEELING ANGLE: 165° ~180°

THIS DOCUMENT IS THE SOLE PROPERTY OF BBJconn Technology Co.,Ltd. Corporation AND SHOULD NOT BE USED IN WHOLE PRIOR WRITTEN PERMISSION.		<b>深圳市步步精科技有限公司</b>	
.X: ±0.38 .XX: ±0.25 .XXX: ±0.13		X': ±3" X'': ±2" .XX': ±1"	
APPD	JM_Zheng	NAME: TYPE-C 16P 母座 90度 沉板2.40 四脚插 端子SMT L=6.50 带中夹片 编带 战斗版	
CHKD	LYX	PJ NO: 126-221-160039-M3G SIZE:A4 DRW NO:	
PDWG NO: 0851-1		FINISH:SEE NOTES SCALE:N/A	
DR	SGF	MAT'L:SEE NOTES REV:AO UNIT:mm PAGE:2/2	