

REV	ECN NO	CONTENT	DATE	ENGINEER
A0		INITIAL RELEASE	/	SGF

SPECIFICATION:

- ELECTRICAL CHARACTERISTICS:
  - CURRENT RATING: 3A
  - TEMPERATURE RANGE: -40 °C ~ 85 °C
  - CONTACT RESISTANCE: 30 MILLIONHM MAX.
  - DIELECTRIC WITHSTANDING VOLTAGE: 100 VAC r.m.s
  - INSULATION RESISTNACE: 100 MEGOHMS MIN.
- MECHANICAL CHARACTERISTICS
  - INSERTION FORCE: 5~20N
  - EXTRACTION FORCE: Initial:8~20N,ATER TEST 6~20N
  - DURABILITY:10,000CYCLES
- THE SHELL LENTH IS LESS THAN THE MINIMUM SPECIFIED BY THE USB TYPE C STANDARD,AS SUCH IS CANNOT INDENOENDENTLY BE GUARANTEED TO MEET ALL TYPE C MECHANICAL REQUIREMENTS.

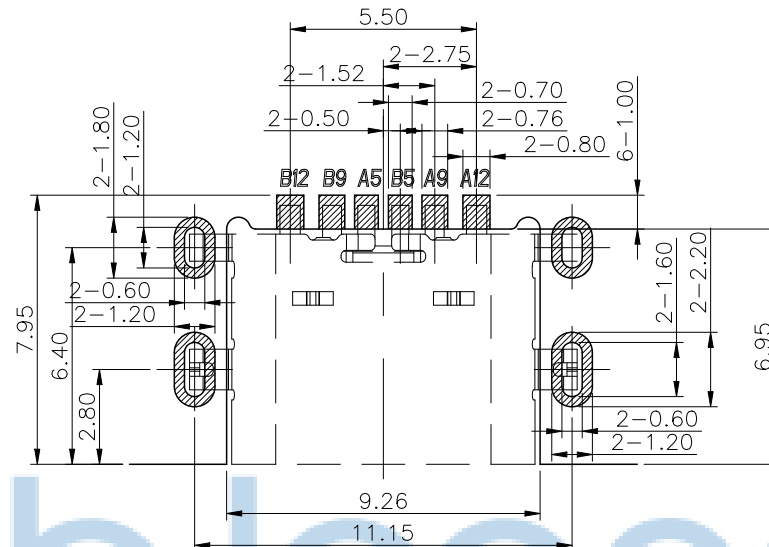
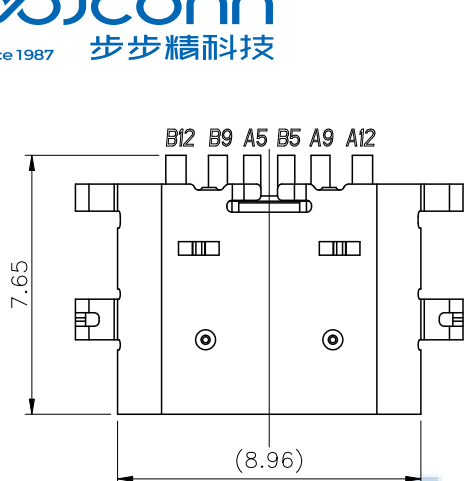

P.C.B LAYOUT VIEW TOLERANCE ±0.05

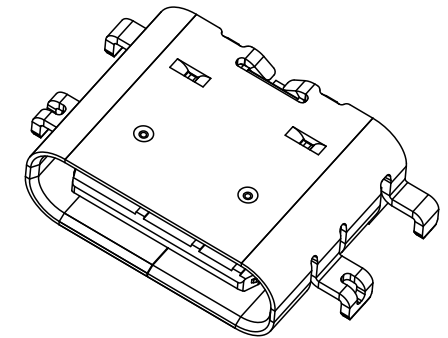
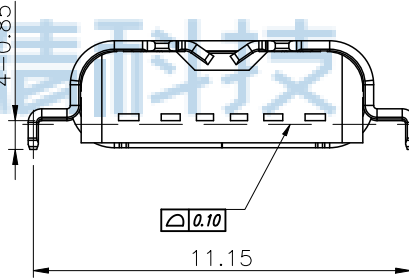
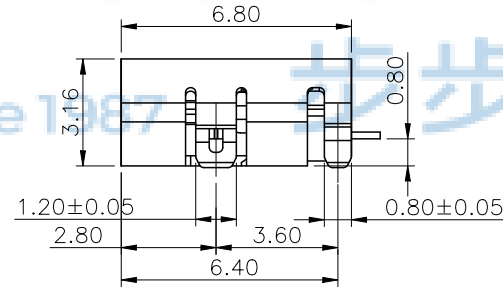
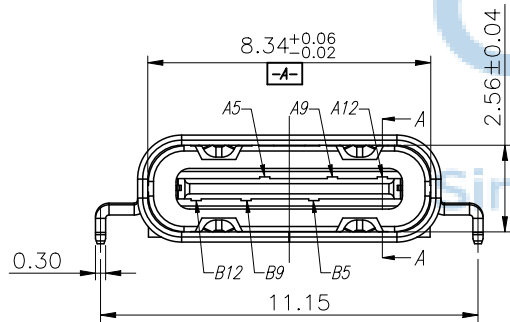

PIN ASSIGNMENT												BLADE	SHELL
A1	A2	A3	A4	A5	A6	A7	A8	A9	A10	A11	A12		
GND	TX1+	TX1-	VBUS	CC1	D+	D-	SBU1	VBUS	RX2-	RX2+	GND		
GND	RX1+	RX1-	VBUS	SBU2	D+	D-	CC2	VBUS	RX2-	RX2+	GND	GND	GND
B12	B11	B10	B9	B8	B7	B6	B5	B4	B3	B2	B1		

2	I/M HOUSING	1 PCS	LPC+C2680+SUS30	Au & Ni Plated
1	SHELL	1 PCS	SUS201	Ni Plated
NO.	DESCRIPTION	QTY.	MATERIAL	FINISHED

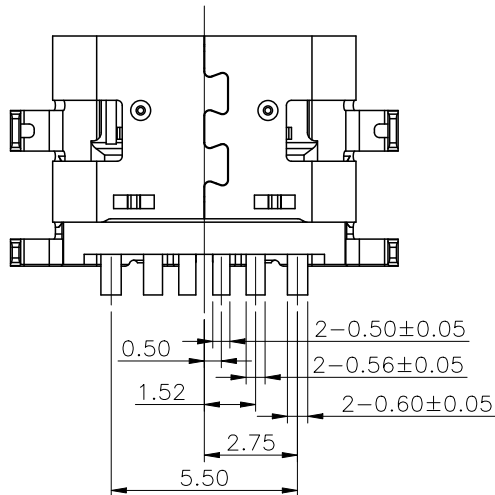

THIS DOCUMENT IS THE SOLE PROPERTY OF BBJconn Technology Co.,Ltd. Corporation AND SHOULD NOT BE USED IN WHOLE PRIOR WRITTEN PERMISSION.

PDWG NO: 0851-1

**深圳市步步精科技有限公司**

NAME: TYPE-C 6P 母座 四脚插 端子SMT 沉板0.8 带中夹片 L=6.80 编带(战斗版)

APPD	JM_Zheng		PJ NO: 126-221-060011-M3G	
CHKD	LYX		SIZE:A4	DRW NO:
DR	SGF	FINISH:SEE NOTES	MAT'L:SEE NOTES	
		SCALE:N/A	REV:A0	UNIT:mm PAGE:1/2

REV	ECN NO	CONTENT	DATE	ENGINEER
AO		INITIAL RELEASE	/	SGF

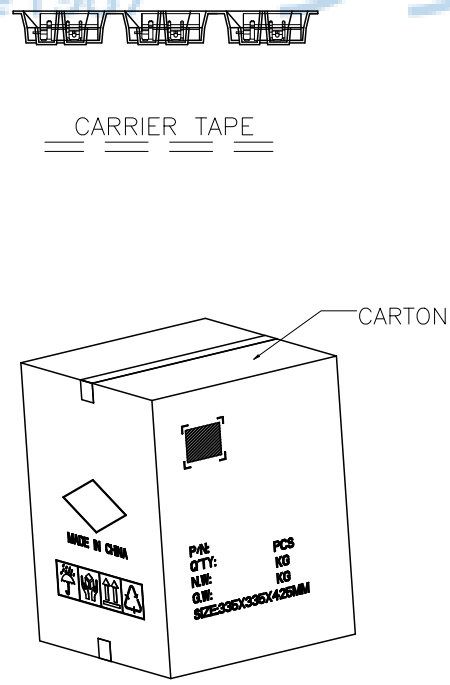
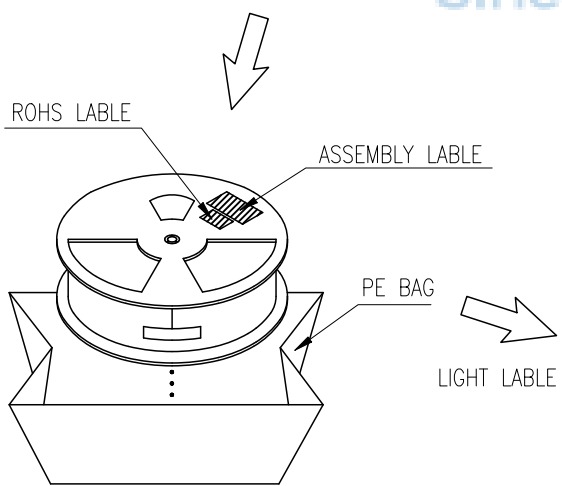
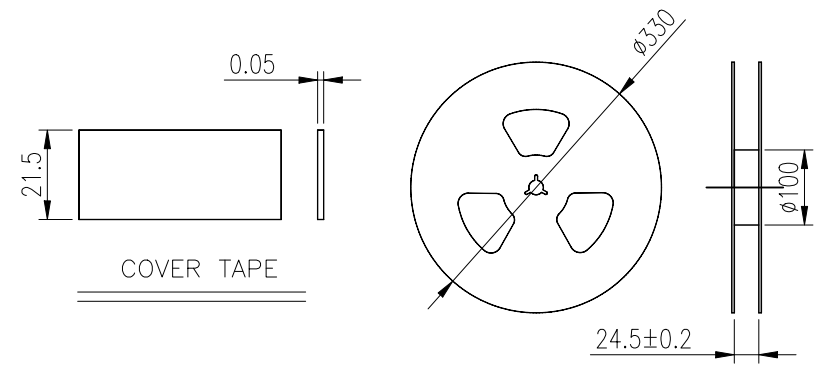
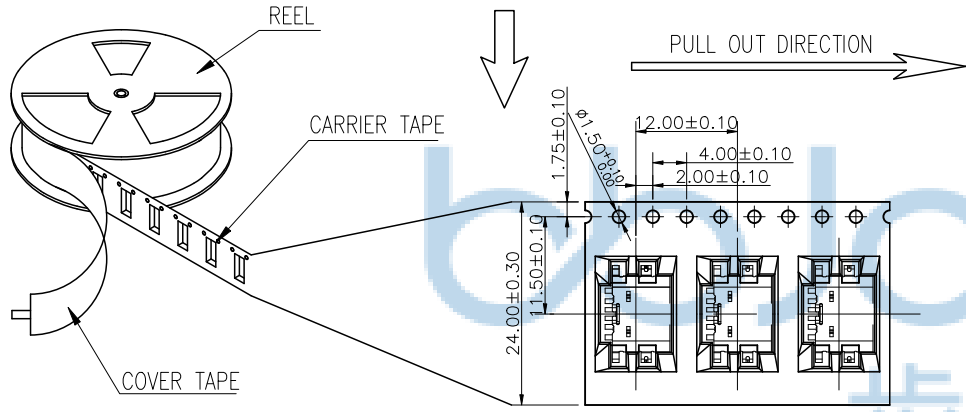
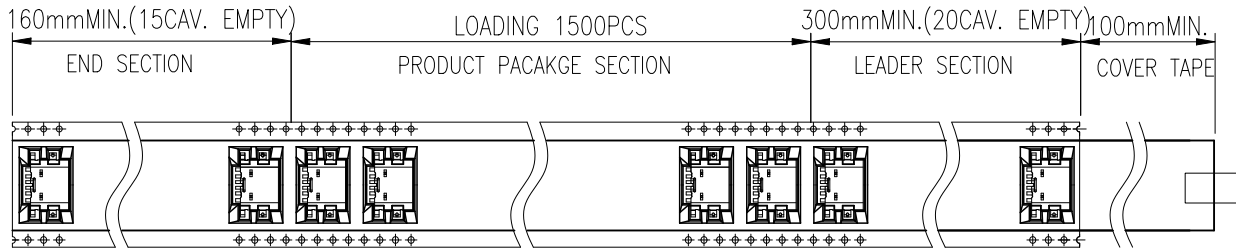

- NOTES 2:
- MATERIAL:
    - 1.1 REEL AND AXLE: PS,BLUE
    - 1.2 CARRIER TAPE: PET, LUCID
    - 1.3 COVER TAPE: PS,TRANSPARENT
    - 1.4 SHIPPING CARTON: CORRUGATED FIBER
  - DIMENSION:
    - 2.1 REEL: W=24.5, ØA=330
    - 2.2 CARRIER TAPE: T=0.30 W=24.0
    - 2.3 COVER TAPE: T=0.05 W=21.5
    - 2.4 SHIPPING CARTON: L=335mm, W=335mm, H=425mm
  - QUANTITY :
    - 3.1 PRIMAY PACKING: 1500PCS/REEL
    - 3.2 SECONARY PACKING: 12 REELS/CARTON(18000PCS/CARTON)
  - PEELING RESISTANCE: 0.1~1.3N
    - 4.1 PEELING SPEED: 300mm/minutes
    - 4.2 PEELING ANGLE: 165° ~180°



THIS DOCUMENT IS THE SOLE PROPERTY OF BBJconn Technology Co.,Ltd. Corporation AND SHOULD NOT BE USED IN WHOLE PRIOR WRITTEN PERMISSION.	深圳市步步精科技有限公司 工程部		NAME: TYPE-C 6P 母座 四脚插 端子SMT 沉板0.8 带中夹片 L=6.80 编带 (战斗版)	
	.X: ±0.38 .XX: ±0.25 .XXX: ±0.13	X': ±3" .X': ±2" .XX': ±1"	APPD: JM_Zheng CHKD: LYX DR: SGF	PJ NO: 126-221-060011-M3G SIZE:A4 FINISH:SEE NOTES SCALE:N/A
PDWG NO: 0851-1				