

REV.	ECN NO	CONTENT	DATE	ENGINEER
A0		Initial release	/	TSP

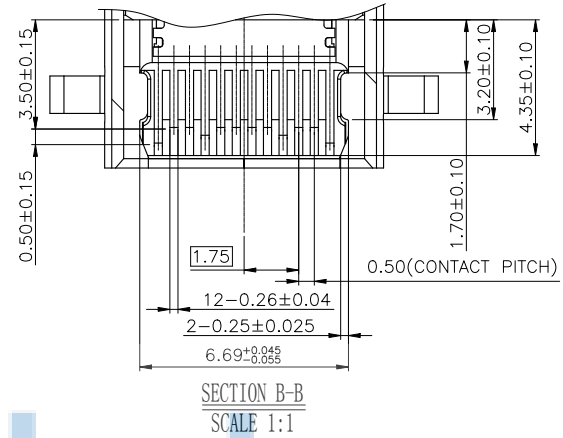

- NOTES:
- MATERIAL:
MOLDING: LCP UL94 V-0
CONTACT: COPPER ALLOY.
PLATED GOLD ON CONTACT AREA,
G/F GOLD ON SOLDER AREA,
50u" NICKEL PLATING OVER ALL.
SHELL: SUS304-H, T=0.30±0.03mm
50u" NICKEL PLATING OVER ALL.
SHILD: SUS304-H, T=0.12±0.03mm
 - MECHANICAL:
INSERTION: 5~20N.
EXTRACTION: 8~20N.
DURABILITY: 10000 CYCLES
 - ELECTRICAL:
CURRENT: 5A MAX FOR VBUS;
1.25A FOR GND, 0.25A FOR OTHER OTHER.
VOLTAGE: 20VDC MAX
WITHSTANDING VOLTAGE: 100V AC.
CONTACT RESISTANCE: 40mΩ MAX.
INSULATION RESISTANCE: 100MΩ MIN.
 - ENVIRONMENTAL
TEMPERATURE RANGE: -30°C TO +80°C

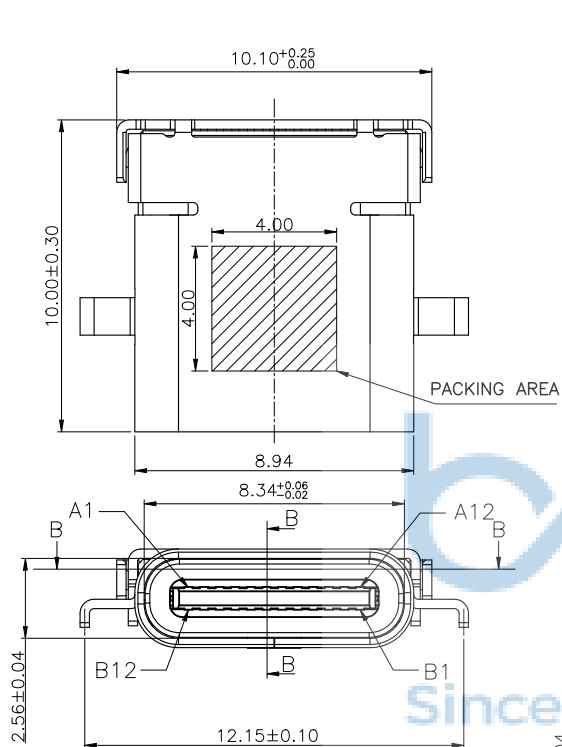
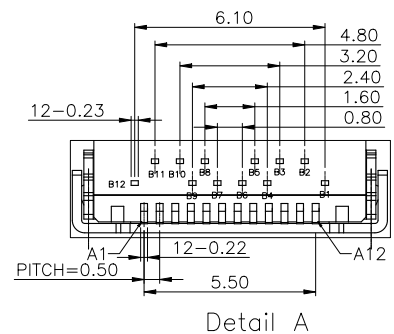
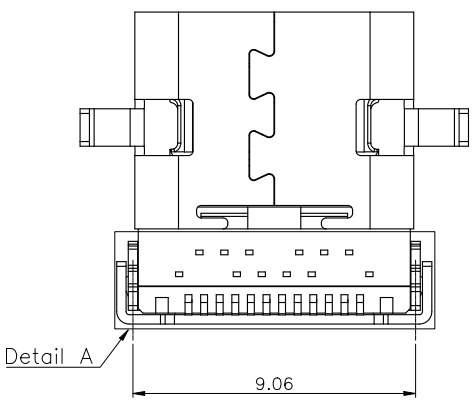
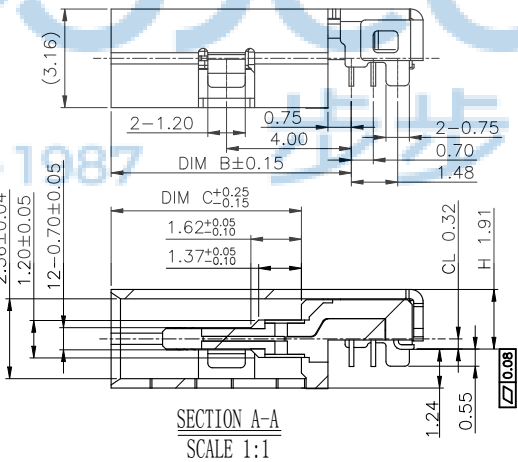

NO	DIM A	DIM B	DIM C
3	10.0	7.75	6.2
4	8.65	6.4	4.85
	--	--	--

THIS DOCUMENT IS THE SOLE PROPERTY OF BBJconn Technology Co., Ltd. Corporation AND SHOULD NOT BE USED IN WHOLE OR IN PART WITHOUT PRIOR WRITTEN PERMISSION. PDWG,NO: 0228-1

深圳市步步精科技有限公司

NAME: TYPE-C 24P 母座 单壳 沉板 1.24 SMT+DIP 镀金15U 四脚插 无柱 L=10.0 CH=0.32 编带

APPD. JM_Zheng
CHKD. LYX
DR. TSP

PJ. NO.: 126-223-240031-T7G
SIZE: A4 DRW NO.:
FINISH: SEE NOTES MAT'L.: SEE NOTES
SCALE: N/A REV.: A0 UNIT: mm PAGE: 1/4

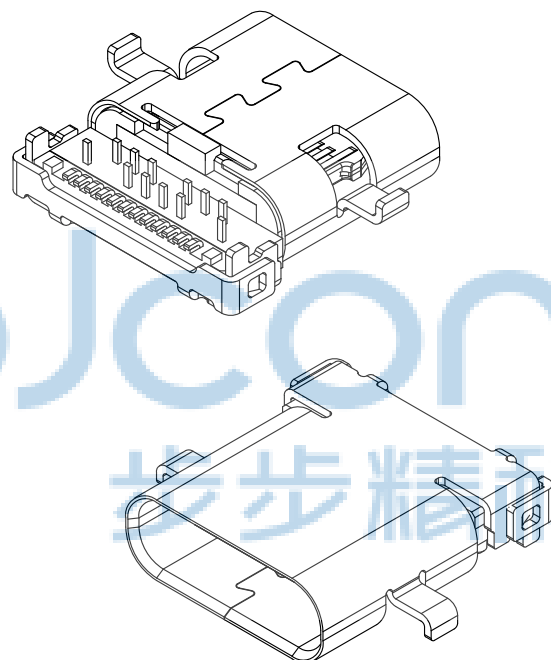
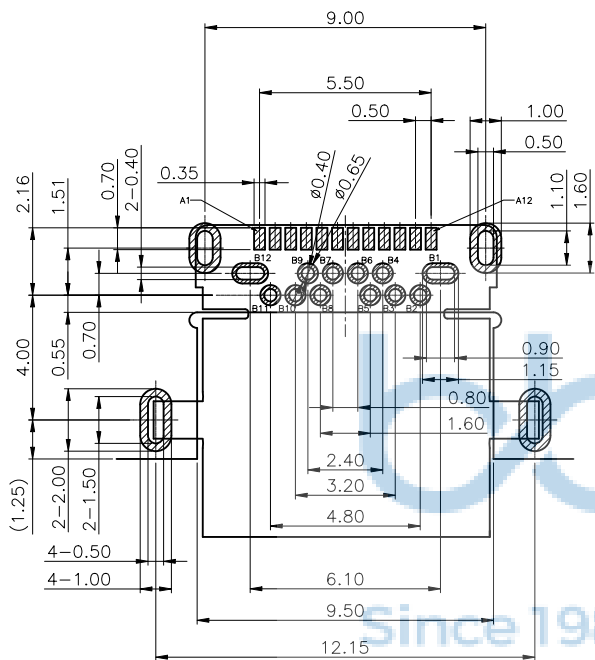

RECOMMEND P.C.B LAYOUT(COMPONENT SIDE)
TOLERANCE FOR PCB LAYOUT IS ± 0.05
KEEP OUT AREA

USB TYPE-C FULL-FEATURED RECEPTACLE INTERFACE PIN ASSIGNMENTS

PIN	Signal Name	Description	PIN	Signal Name	Description
A1	GND	Ground return	B12	GND	Ground return
A2	SSTXp1	Positive half of first SuperSpeed TX differential pair	B11	SSRXp1	Positive half of first SuperSpeed RX differential pair
A3	SSTXn1	Negative half of first SuperSpeed TX differential pair	B10	SSRXn1	Negative half of first SuperSpeed RX differential pair
A4	VBUS	Bus Power	B9	VBUS	Bus Power
A5	CC1	Configuration Channel	B8	SBU2	Sideband Use (SBU)
A6	Dp1	Positive half of the USB 2.0 differential pair-Position 1	B7	Dn2	Negative half of the USB 2.0 differential pair-Position 2
A7	Dn1	Negative half of the USB 2.0 differential pair-Position 1	B6	Dp2	Positive half of the USB 2.0 differential pair-Position 2
A8	SBU1	Sideband Use(SBU)	B5	CC2	Configuraation Channel
A9	VBUS	Bus Power	B4	VBUS	Bus Power
A10	SSRXn2	Negative half of second SuperSpeed RX differential pair	B3	SSTXn2	Negative half of second SuperSpeed TX differential pair
A11	SSRXp2	Positive half of second SuperSpeed RX differential pair	B2	SSTXp2	Positive half of second SuperSpeed TX differential pair
A12	GND	Ground return	B1	GND	Ground return



THIS DOCUMENT IS THE SOLE PROPERTY OF BBJconn Technology Co.,Ltd. Corporation AND SHOULD NOT BE USED IN WHOLE OR IN PART WITHOUT PRIOR WRITTEN PERMISSION.		深圳市步步精科技有限公司 .X: ± 0.38 .X': $\pm 3'$.XX: ± 0.25 .X': $\pm 2'$.XXX: ± 0.13 .XX': $\pm 1'$	
APPD.	JM_Zheng	PJ. NO.: 126-223-240031-T7G SIZE: A4 DRW NO.:	NAME: TYPE-C 24P 母座 单壳 沉板 1.24 SMT+DIP 镀金15U 四脚插 无柱 L=10.0 CH=0.32 编带
CHKD.	LYX		FINISH: SEE NOTES MAT'L.: SEE NOTES
PDWG.NO:	0228-1	DR.	TSP
		SCALE: N/A	REV.: A0 UNIT: mm PAGE: 2/4

REV.	ECN NO	CONTENT	DATE	ENGINEER
A0		Initial release	/	TSP



NOTES

1. 帶子引導長度
LEAD TAPE LENGTH
出料方向
PULL OUT DIRECTEON

2. 上帶剝力力為：0.1~1.3N(10.2gf~130gf)
PEELING OFF FORCE OF TOP TAPE: 0.1~1.3N(10.2gf~130gf)
出貨運輸過程中一定注意：
THIS REQUIREMENT SHOULD BE APPLIED AT SHIPMENT：
卷帶在運輸過程中不能散開
PEELING OFF SHOULD NOT BE ALLOWED DURING TRANSPORTATION

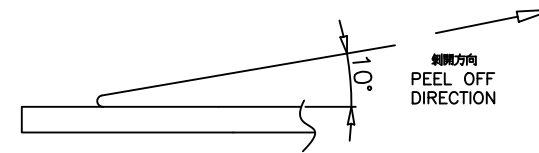
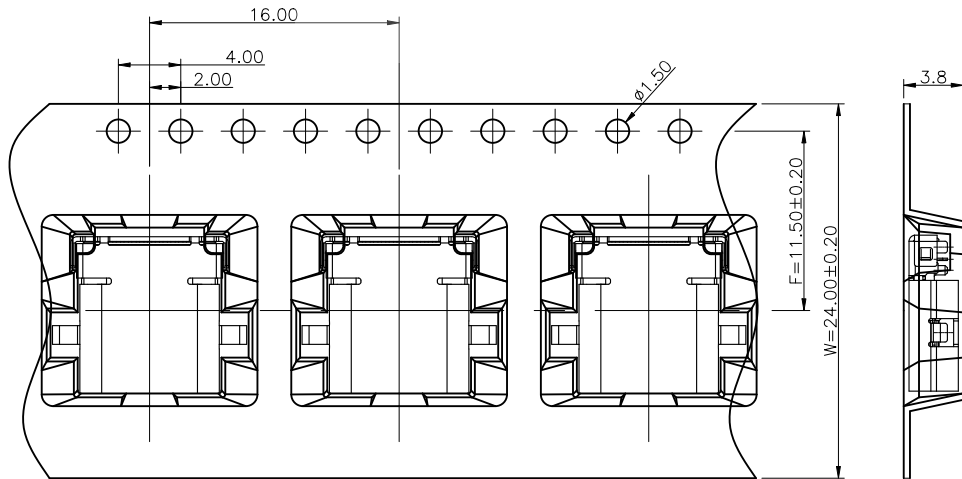
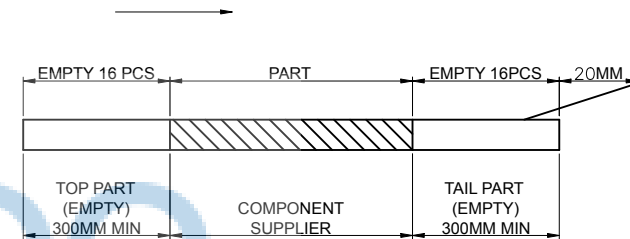
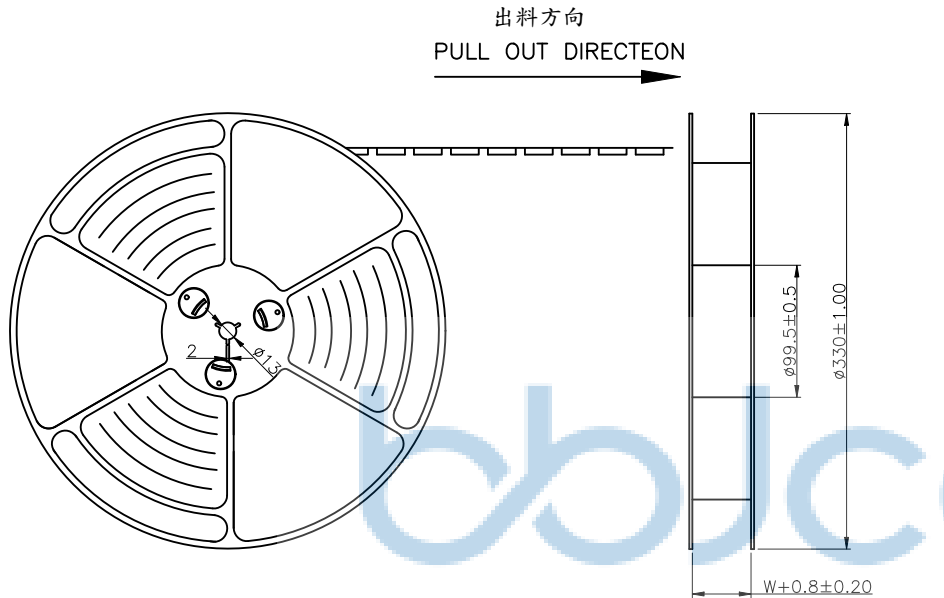

THIS DOCUMENT IS THE SOLE PROPERTY OF		BBJconn Technology Co., Ltd.	
Corporation AND SHOULD NOT BE USED IN WHOLE OR IN PART WITHOUT PRIOR WRITTEN PERMISSION.		PDWG.NO: 0228-1	
NAME:	TYPE-C 24P 母座 单壳 沉板 1.24 SMT+DIP 镀金15U 四脚插 无柱 L=10.0 CH=0.32 编带		
APPD.	JM_Zheng	PJ. NO.:	126-223-240031-T7G
CHKD.	LYX	SIZE:	A4 DRW NO.:
DR.	TSP	FINISH:	SEE NOTES
		MAT'L.:	SEE NOTES
		SCALE:	N/A
		REV.:	A0
		UNIT:	mm
		PAGE:	3/4



Location of label sticking (label at small positioning hole of the carrier tape side).
标签粘贴处 (朝卷装包材的小定位孔一侧)

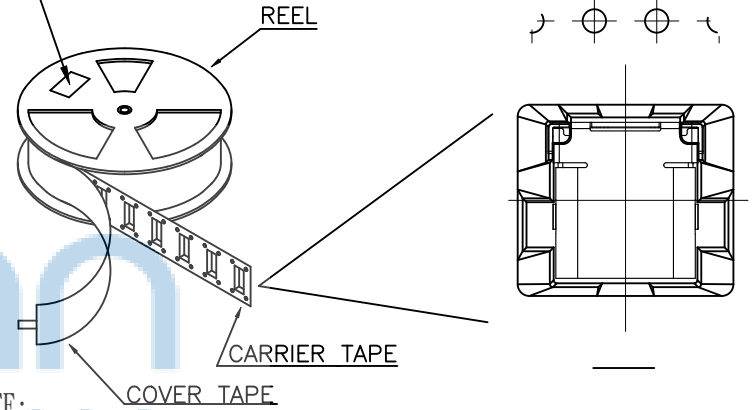
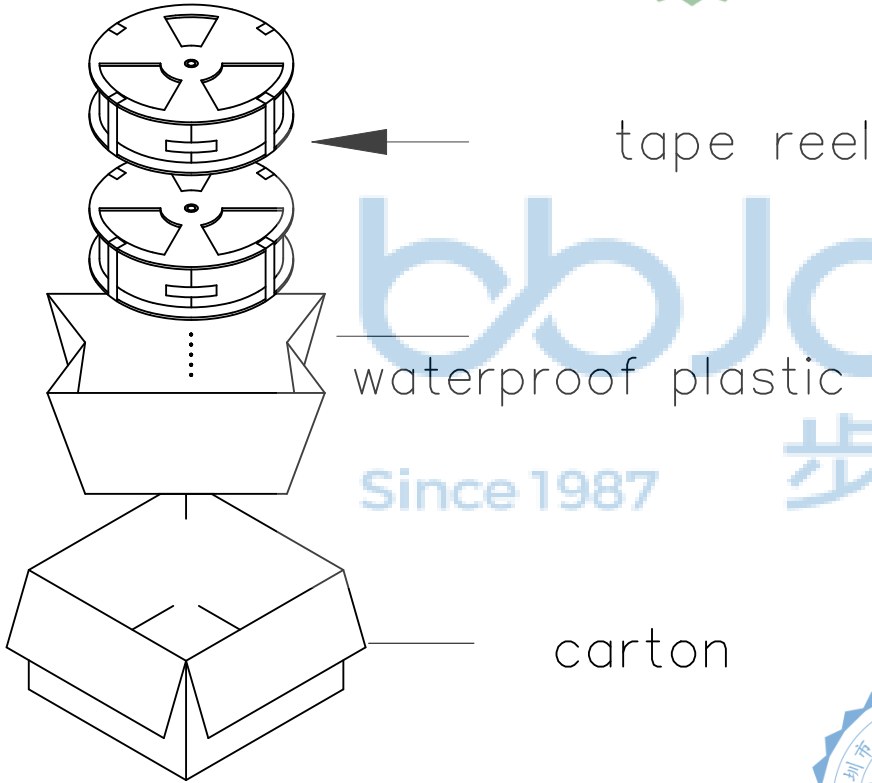

- NOTE:
1. 每捲包裝數量及每箱裝箱數量如左下表格。
Packing q'ty of each reel & carton as below table shown.
 2. 以上膠帶覆蓋下包裝帶經包裝機熱熔包裝
Use cover tape to cover and hot melt machine to seal up.
 3. 將裝滿產品的卷盤放入紙箱並以膠帶封口
Put reels in the carton and use adhesive tape to seal up.



產品料號 (PRODUCT No.)	包裝容量 (PACKING CAPACITY)			重量 WEIGHT (Kg)		
	PCS/REEL	REELS/CARTON	PCS/CARTON	N.W./PCS	N.W./BOX	G.W./BOX
	1000	10	10000	0.76g	7.6Kg	

THIS DOCUMENT IS THE SOLE PROPERTY OF BBJconn Technology Co.,Ltd. CORPORATION AND SHOULD NOT BE USED IN WHOLE OR IN PART WITHOUT PRIOR WRITTEN PERMISSION.		深圳市步步精科技有限公司 .X: ±0.38 .X': ±3" .XX: ±0.25 .X'': ±2" .XXX: ±0.13 .X''': ±1"		NAME: TYPE-C 24P 母座 单壳 沉板1.24 SMT+DIP 镀金15U 四脚插 无柱 L=10.0 CH=0.32 编带	
APPD.	JM_Zheng	PJ. NO.: 126-223-240031-T7G		SIZE: A4 DRW NO.:	
CHKD.	LYX	FINISH: SEE NOTES		MAT'L.: SEE NOTES	
PDWG.NO:	0228-1	DR.	TSP	SCALE: N/A	REV.: A0 UNIT: mm PAGE: 4/4