

REV.	ECN NO.	CONTENT	DATE	ENGINEER
A0		Initial release	/	SGF

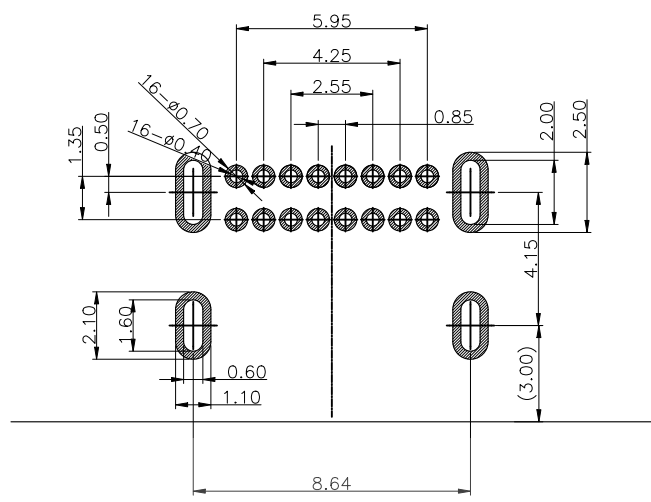

RECOMMEND P.C.B LAYOUT (COMPONENT SIDE)
TOLERANCE FOR PCB LAYOUT IS ± 0.05
KEEP OUT AREA

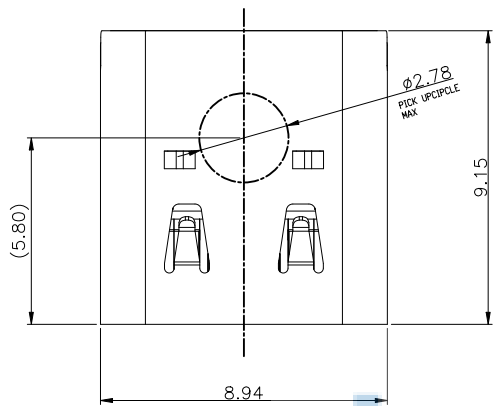
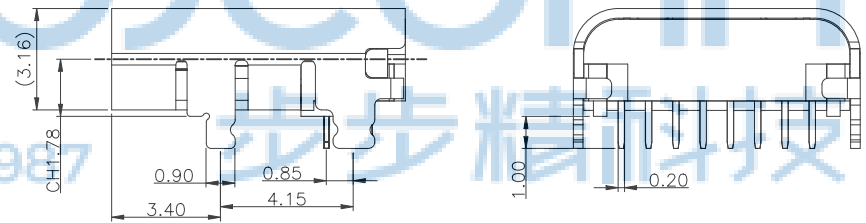
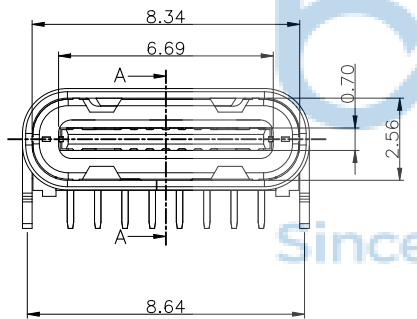

- NOTES:
- MATERIAL:**
MOLDING: LCP UL94 V-0
CONTACT: COPPER ALLOY.
GOLD PLATED Min ON CONTACT AREA, 100u"
Min TIN (LEAD FREE) ON SOLDER AREA,
SHELL: SUS304-H, T=0.30±0.03mm
50u" NICKEL PLATING OVER ALL.
MIDDLE SHILD: SUS301-H, T=0.15±0.03mm
 - MECHANICAL:**
INSERTION: 5~20N.
EXTRACTION: 8~20N AFTER TEST.
DURABILITY: 10000 CYCLES
 - ELECTRICAL:**
CURRENT: 5A FOR VBUS;
1.25A FOR GND PIN.
0.25A FOR OTHER.
VOLTAGE: 20 V MAX
WITHSTANDING VOLTAGE: 100V AC R.M.S.
CONTACT RESISTANCE: 40mΩ MAX.
INSULATION RESISTANCE: 100MΩ MIN.
 - ENVIRONMENTAL**
TEMPERATURE RANGE -35°C ~ +85°C



USB TYPE-C PIN ASSIGNMENTS

PIN NUMBER	SIGNAL NAME	PIN NUMBER	SIGNAL NAME
A1	GND	B12	GND
A4	VBUS	B9	VBUS
A5	CC1	B8	SBU2
A6	Dp1	B7	Dn2
A7	Dn1	B6	Dp2
A8	SBU1	B5	CC2
A9	VBUS	B4	VBUS
A12	GND	B1	GND

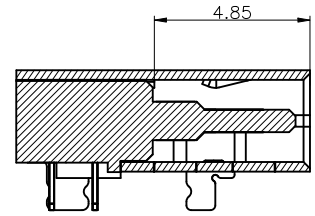
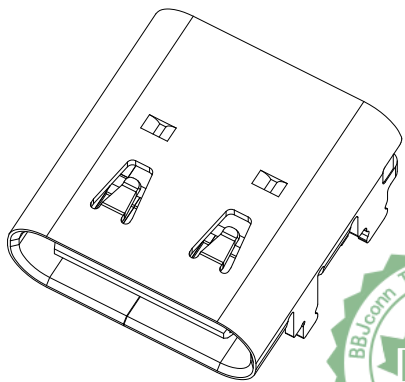
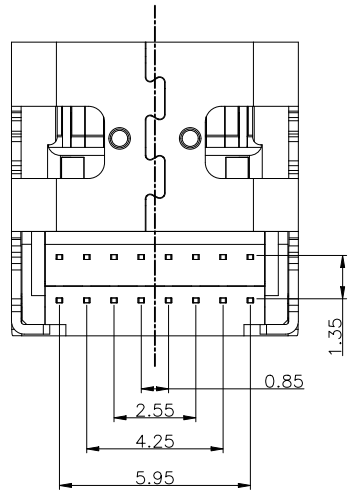

SECTION A-A



THIS DOCUMENT IS THE SOLE PROPERTY OF BBJconn Technology Co., Ltd. Corporation AND SHOULD NOT BE USED IN WHOLE OR IN PART WITHOUT PRIOR WRITTEN PERMISSION.
PDWG. NO: 0627-1

深圳市步步精科技有限公司

NAME: TYPE-C 16P 母座 L=9.15 CH=1.78 板上四脚插 双排DIP 铜壳 端子脚长1.00 编带

APPD. JM_Zheng
CHKD. LYX
DR. SGF

PJ. NO.: 126-222-160001-J4G
SIZE: A4 DRW NO.:
FINISH: SEE NOTES MAT'L.: SEE NOTES
SCALE: N/A REV.: A0 UNIT: mm PAGE: 1/2

REV.	ECN NO.	CONTENT	DATE	ENGINEER
A0		Initial release	/	SGF

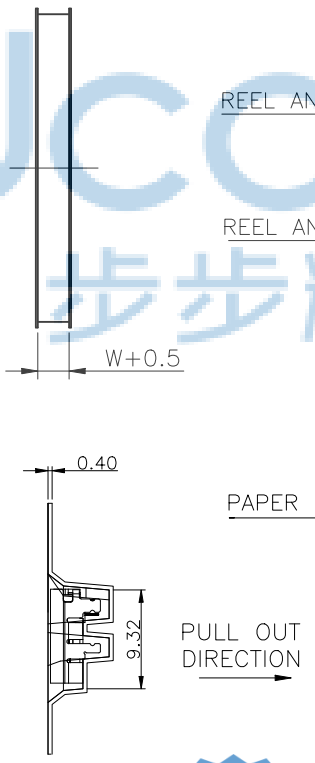
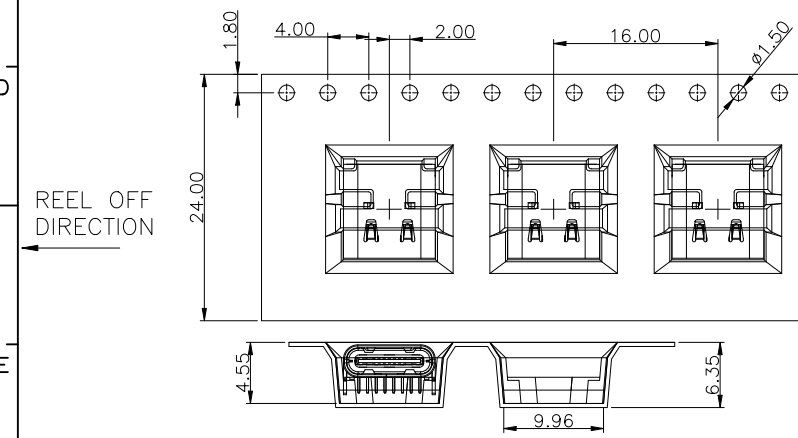
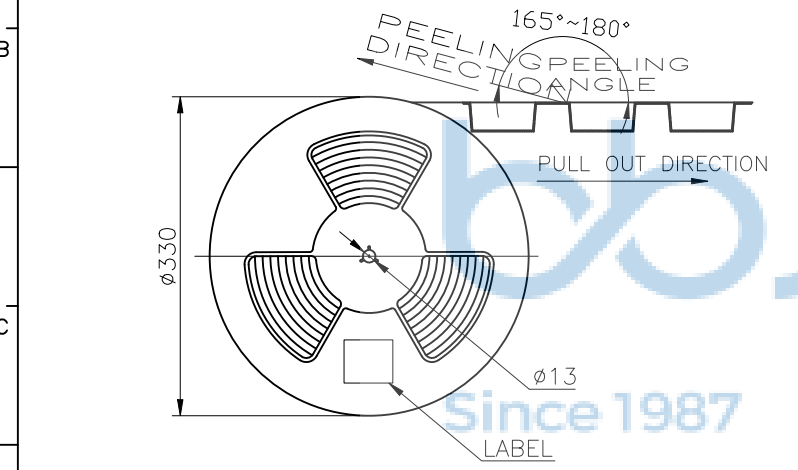
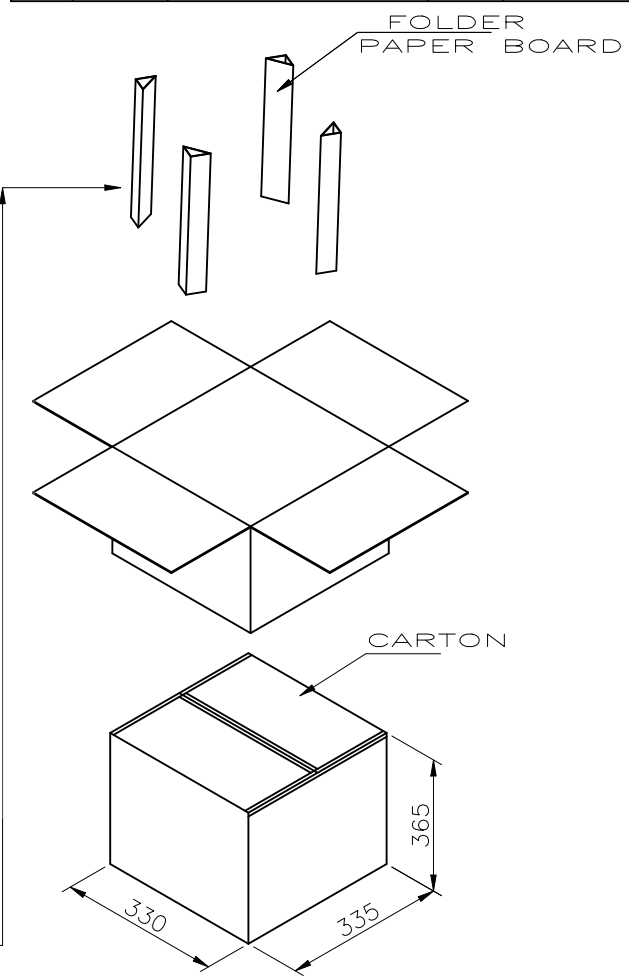
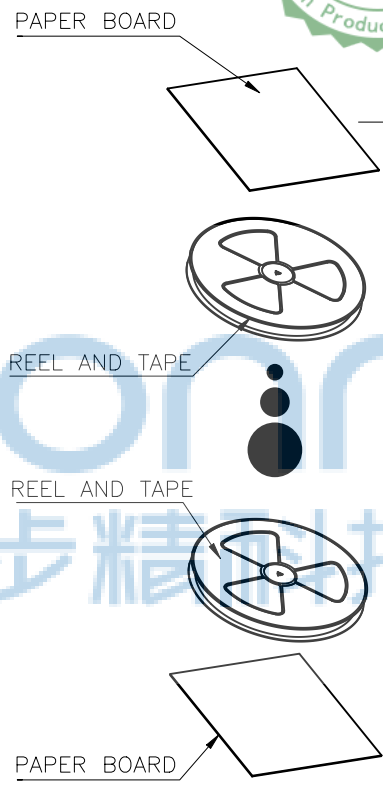
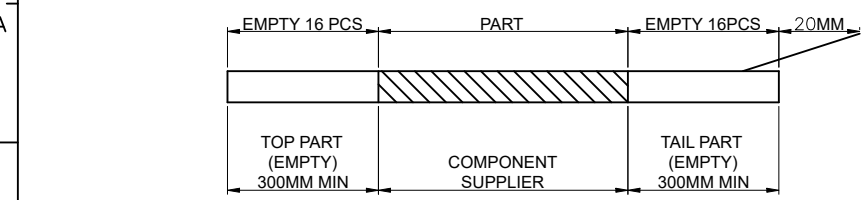

	REEL	CARTON
CONNECTOR (PCS)	1000	10000

THIS DOCUMENT IS THE SOLE PROPERTY OF BBJconn Technology Co., Ltd. Corporation AND SHOULD NOT BE USED IN WHOLE OR IN PART WITHOUT PRIOR WRITTEN PERMISSION.		深圳市步步精科技有限公司 NAME: TYPE-C 16P 母座 L=9.15 CH=1.78 板上四脚插 双排DIP 铜壳 端子脚长1.00 编带 APPD. JM_Zheng CHKD. LYX DR. SGF PDWG.NO: 0627-1	
.X: ±0.38	.XX: ±0.25	.XXX: ±0.13	X': ±3' X'': ±2' XX': ±1'
PJ. NO.: 126-222-160001-J4G SIZE: A4 DRW NO.: FINISH: SEE NOTES MAT'L.: SEE NOTES SCALE: N/A REV.: A0 UNIT: mm PAGE: 2/2			