

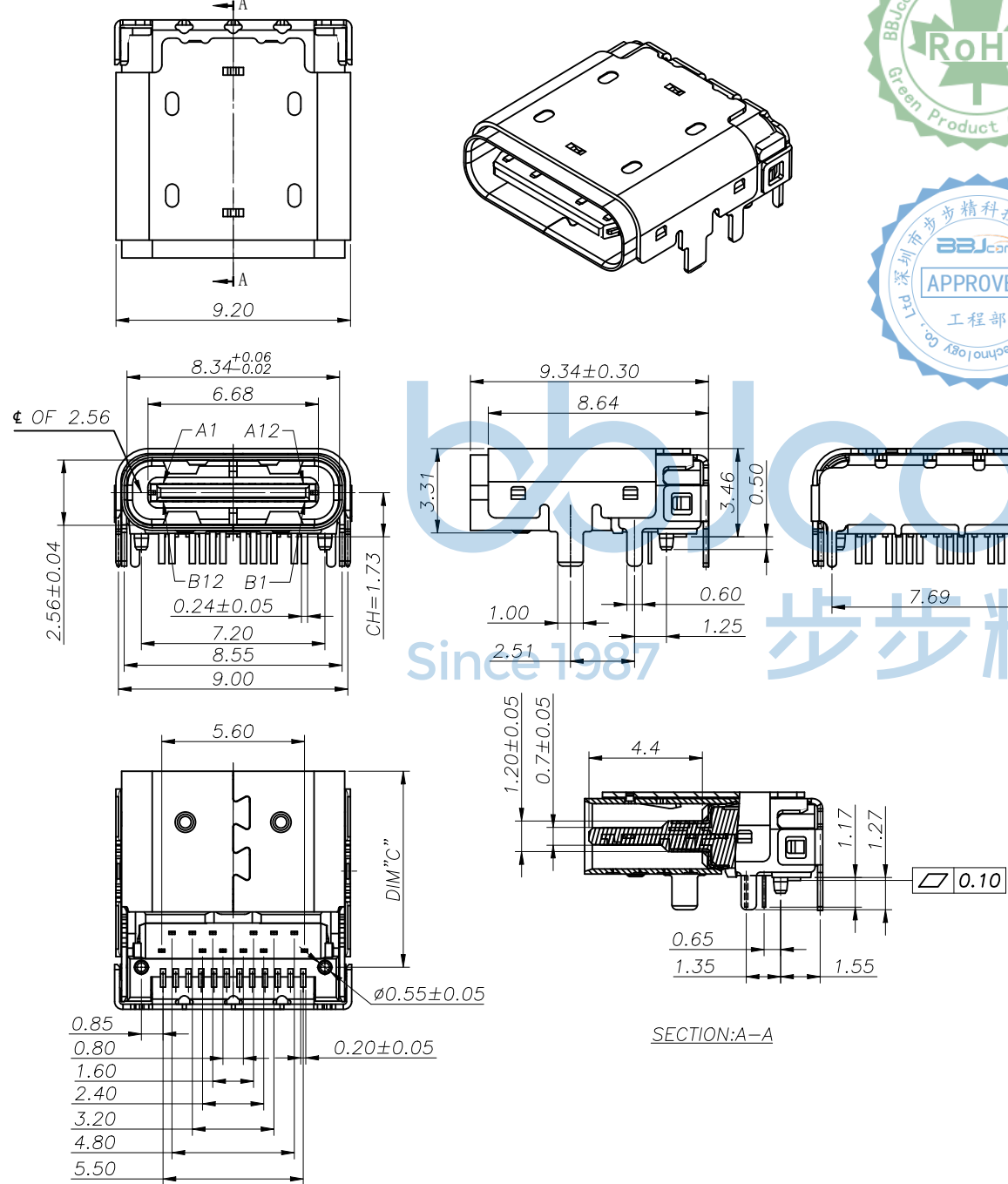

REV.	ECN NO	CONTENT	DATE	ENGINEER
A0		Initial release	/	TSP

NOTE:

- MATERIAL SPECIFICATION:
  - HOUSING: PA9T COLOR BALCK ,UL94 V-0.
  - CONTACTS: COPPER ALLOY(C1815)
  - MID PLATE & SPRING: STAINLESS STEEL(SUS301)
  - FRONT SHELL & COVER: STAINLESS STEEL(SUS304)
- PLATING SPECIFICATION:
  - CONTACTS:
    - Ni 50u" MIN. UNDER PLATED OVER ALL.
    - Au 3u" PLATED ON THE FUNCTIONAL AREA OF CONTACT. (GOLD PLATING THICKNESS FOLLOW G/F)
  - FRONT SHELL & COVER:
    - Ni 30u" MIN. UNDER PLATED OVER ALL.
  - MID PLATE & EMI SPRING:
    - CLEAR ONLY
- MECHANICAL PERFORMANCE,
  - INSERTION FORCE: 0.5~2.0kgf.
  - REMOVAL FORCE: 0.8kgf~2.0kgf.
  - DURABILITY: 10000 CYCLES.
- ELECTRICAL PERFORMANCE,
  - CURRENT RATING: 3.0A  
VOLTAGE RATING: 5.0V
  - LLCR:
    - VBUS & GND PINS AND OTHER PINS: 40mA/PIN MAX.
    - LLCR MAX. CHANGE OF ALL PINS: 10mA.
  - INSULATION RESISTANCE: 100MΩ MIN
  - DIELECTRIC WITHSTAND VOLTAGE, AC 100V FOR 1 MINUTE.
- ENVIRONMENTAL PERFORMANCE:
  - OPERATING TEMPERATURE: -25°C~+85°C.
- IR REFLOW:
  - THE PEAK TEMPERATURE ON THE BOARD SHALL BE MAINTAINED FOR 10 SECONDS AT 260°C.



THIS DOCUMENT IS THE SOLE PROPERTY OF BBJconn Technology Co., Ltd. Corporation AND SHOULD NOT BE USED IN WHOLE OR IN PART WITHOUT PRIOR WRITTEN PERMISSION.		深圳市步步精科技有限公司	
.X: ±0.38 .XX: ±0.25 .XXX: ±0.13		X': ±3' .X': ±2' .XX': ±1'	
APPD.	JM_Zheng	NAME: TYPE-C 24P 母座 双壳 SMT+DIP 板上六脚插 带柱 L=9.34 CH=1.73 编带	
CHKD.	LYX	PJ. NO.: 126-223-240002-M8G SIZE: A4   DRW NO.:	
PDWG.NO:	0049-1	FINISH: SEE NOTES	MAT'L.: SEE NOTES
DR.	TSP	SCALE: N/A	REV.: A0   UNIT: mm   PAGE: 1/3



REV.	ECN NO	CONTENT	DATE	ENGINEER
A0		Initial release	/	TSP

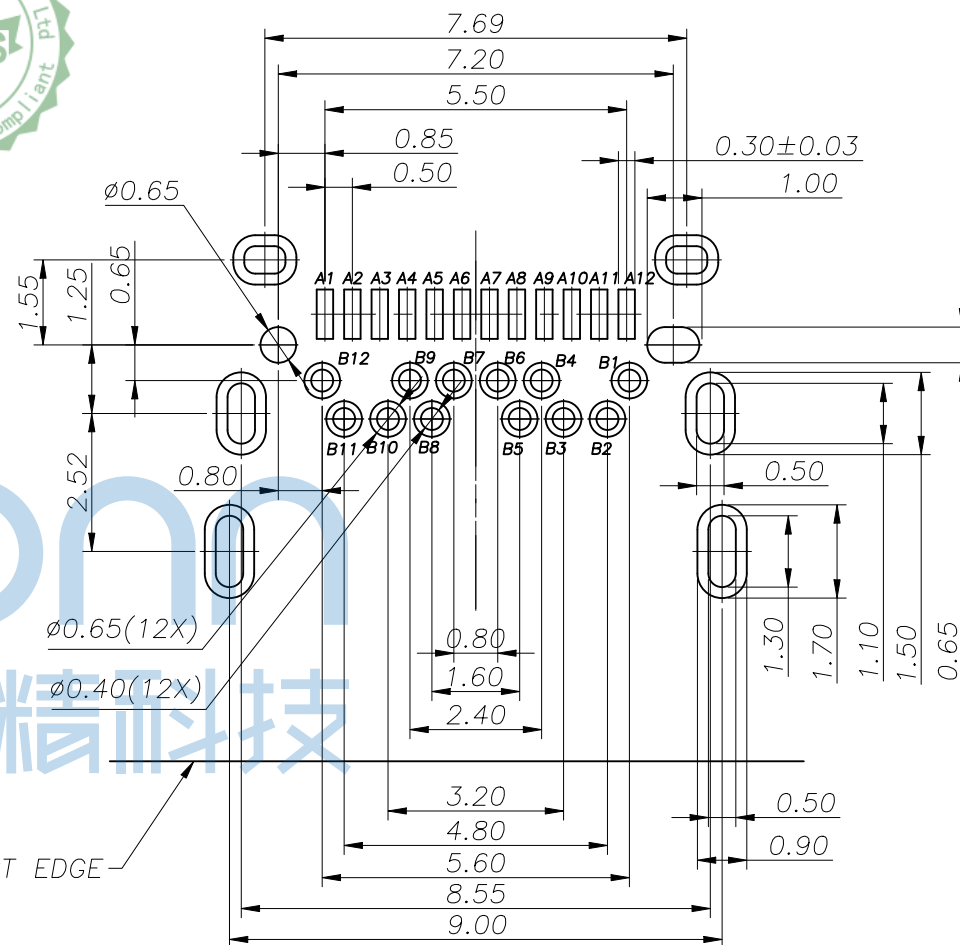
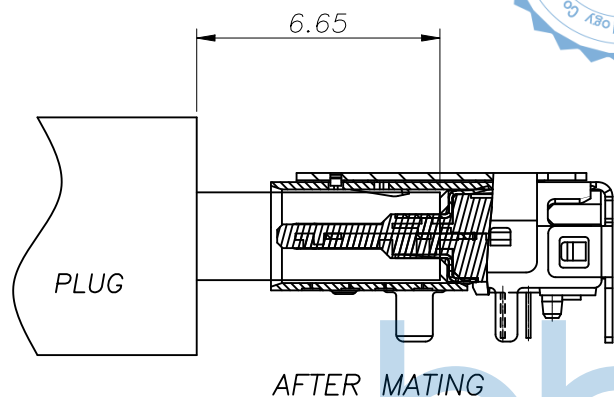

USB TYPE-C PIN ASSIGNMENTS

PIN NUMBER	SIGNAL NAME	PIN NUMBER	SIGNAL NAME
A1	GND	B12	GND
A2	SSTXp1	B11	SSRXp1
A3	SSTXn1	B10	SSRXn1
A4	Vbus	B9	Vbus
A5	CC1	B8	SBU2
A6	Dp1	B7	Dn2
A7	Dn1	B6	Dp2
A8	SBU1	B5	CC2
A9	Vbus	B4	Vbus
A10	SSRXn2	B3	SSTXn2
A11	SSRXp2	B2	SSTXp2
A12	GND	B1	GND

SCALE 1.5:1

RECOMMENDED PCB LAYOUT(TOP VIEW)  
THICKNESS 1.0 MM;DEFAULT TOLERANCE:±0.05

THIS DOCUMENT IS THE SOLE PROPERTY OF BBJconn Technology Co.,Ltd. Corporation AND SHOULD NOT BE USED IN WHOLE OR IN PART WITHOUT PRIOR WRITTEN PERMISSION.		深圳市步步精科技有限公司 .X: ±0.38 X': ±3" .XX: ±0.25 .X': ±2" .XXX: ±0.13 .XX': ±1"		NAME: TYPE-C 24P 母座 双壳 SMT+DIP 板上六脚插 带柱 L=9.34 CH=1.73 带带	
APPD.	JM_Zheng	PJ. NO.: 126-223-240002-M8G		SIZE: A4 DRW NO.:	
CHKD.	LYX	FINISH: SEE NOTES		MAT'L.: SEE NOTES	
PDWG.NO:	0049-1	DR.	TSP	SCALE: N/A	REV.: A0 UNIT: mm PAGE: 2/3

REV.	ECN NO	CONTENT	DATE	ENGINEER
A0		Initial release	/	TSP

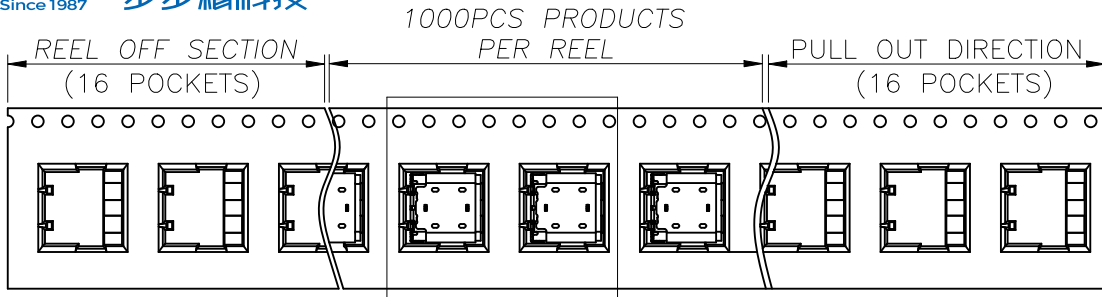

1000PCS PRODUCTS PER REEL

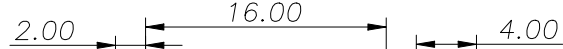
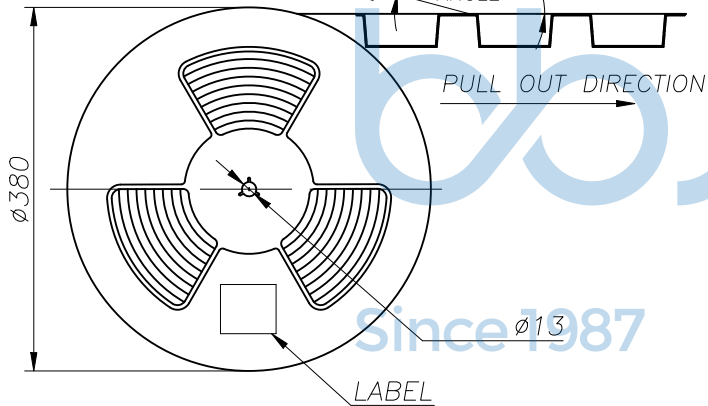
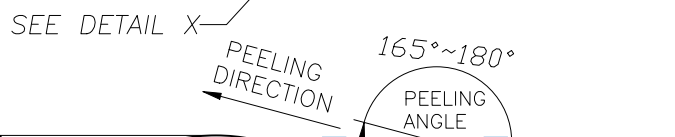

REEL OFF DIRECTION

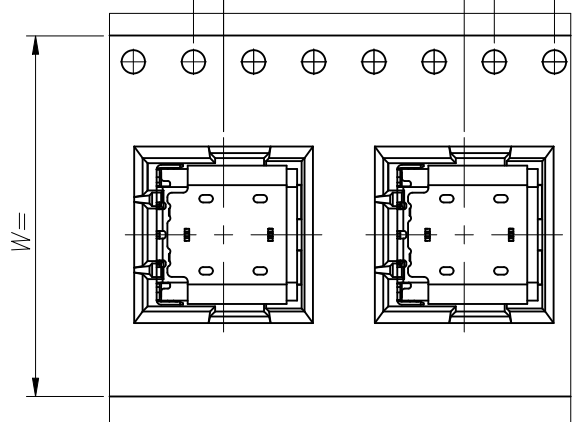

DETAIL X  
SCALE 2:1

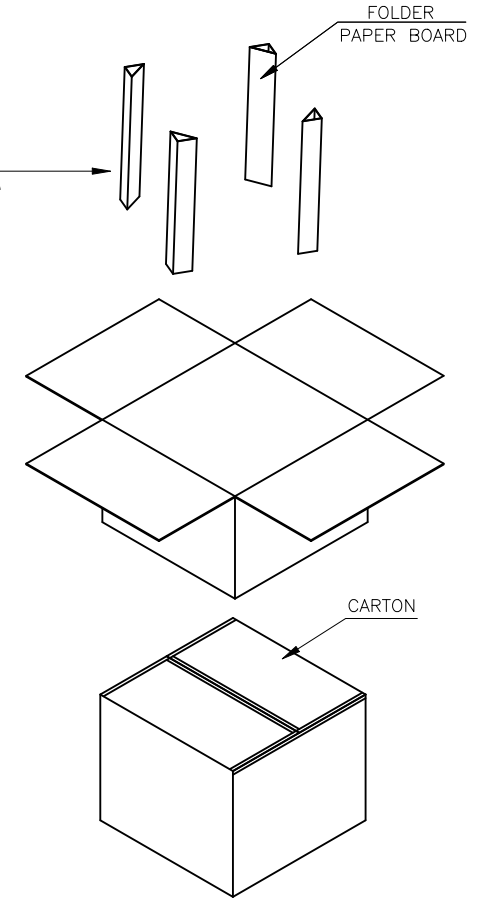
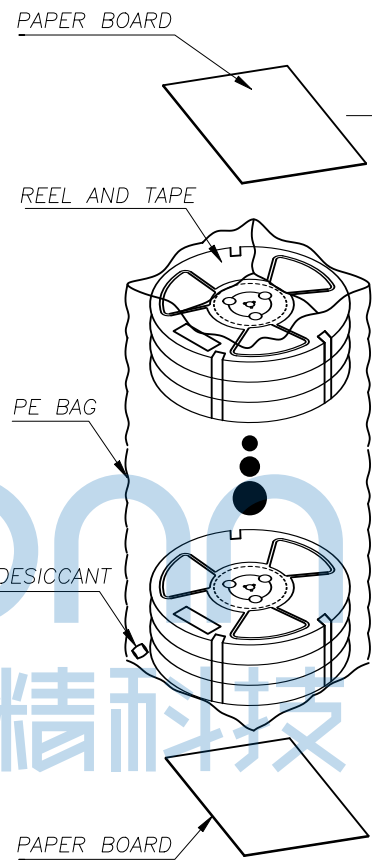

	REEL/TRAY	CARTON
CONNECTOR (PCS)	1000	10000

THIS DOCUMENT IS THE SOLE PROPERTY OF BBJconn Technology Co., Ltd. Corporation AND SHOULD NOT BE USED IN WHOLE OR IN PART WITHOUT PRIOR WRITTEN PERMISSION.

PDWG.NO: 0049-1

DR. TSP

APPD. JM\_Zheng

CHKD. LYX

NAME: TYPE-C 24P 母座 双壳 SMT+DIP 板上六脚插 带柱 L=9.34 CH=1.73 编带

PJ. NO.: 126-223-240002-M8G

SIZE: A4 | DRW NO.:

FINISH: SEE NOTES | MAT'L.: SEE NOTES

SCALE: N/A | REV.: A0 | UNIT: mm | PAGE: 3/3

深圳市步步精科技有限公司