



REV.	DESCRIPTION	NAME	DATE
A	NEWS ISSUE		

NOTES:

SPECIFICATION:

- CURRENT RATING: 3.0A MAX
- VOLTAGE: 100 VAC
- TEMPERATURE RANGE: -30 ° C ~ 85 ° C
- CONTACT RESISTANCE: 40 MILLIONHM MAX
- INSULATION RESISTANCE: 100 MEGOHMS MIN.
- INSERTION FORCE : 5N~20N
- UNMATING FORCE: 8N~20N
- DURABILITY: 10,000 CYCLES

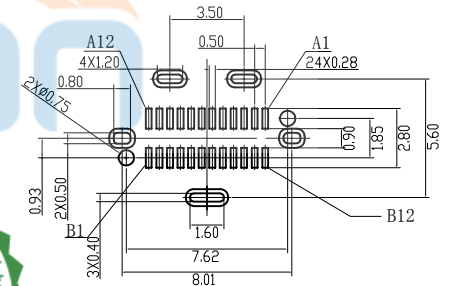
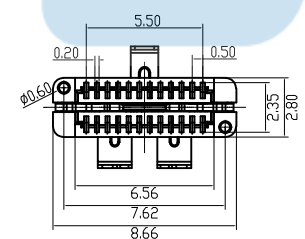
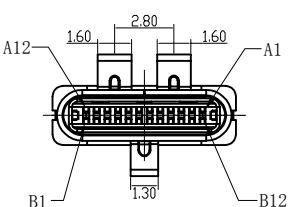
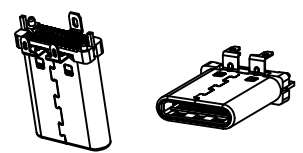
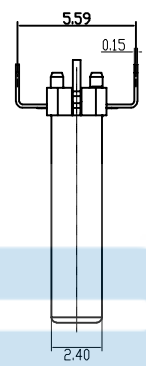
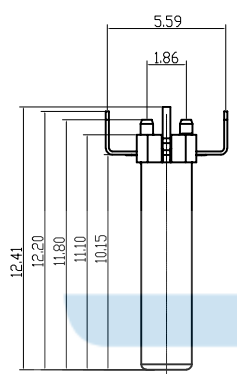
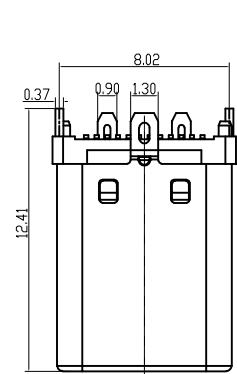

RECOMMENDED PCB LAYOUT(L=0.80±0.05)  
COMPONENT SIDE(GENERAL TOLERANCE:±0.05)

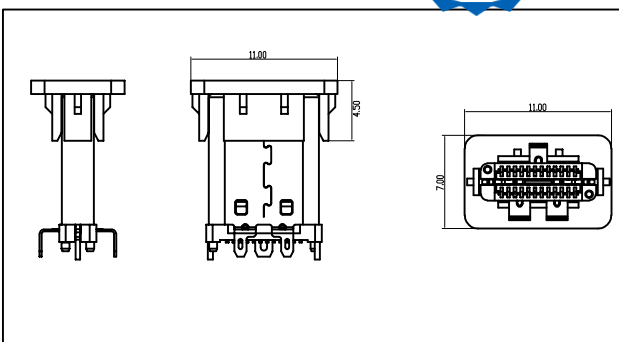
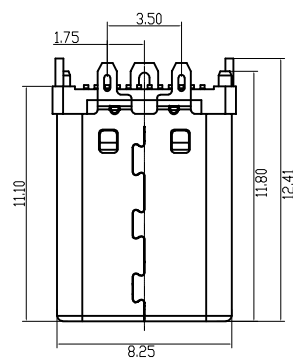

5	COVER	HIGH TEMPERATURE PLASTIC	LCP BLACK	1PCS
4	SPRING	STAINLESS STEEL	---	2PCS
3	LATCH	STAINLESS STEEL	TIN: 80-120u"Min/Ni base: 50u"Min Plated	1PCS
2	SHELL	STAINLESS STEEL	Ni: 50u"Min Plated	1PCS
1	TERMINAL HOUSING	HIGH TEMPERATURE PLASTIC	LCP BLACK/CONTACT: Au: 3u"Min Ni base: 50u"Min	2PCS
NO.	DESCRIPTION	MATERIAL	REMARKS	QTY

公差尺寸表  
Tolerance  
X ±0.50 X' ±2'  
.X ±0.30 .X' ±1'  
.XX ±0.10 .XX' ±0.5'  
.XXX ±0.05

**BBJconn** 深圳市步步精科技有限公司

TITLE: TYPE-C 24P 直立式公头 H=11.1 双排SMT 三脚插 带定位柱

PIN NUMBER	A1	A2	A3	A4	A5	A6	A7	A8	A9	A10	A11	A12
SIGNAL NAME	GND	SSTXp1	SSTXn1	VBUS	CC1	Dp1	Dn1	SBU1	VBUS	SSRXn2	SSRXp2	GND
PIN NUMBER	B12	B11	B10	B9	B8	B7	B6	B5	B4	B3	B2	B1
SIGNAL NAME	GND	SSRXp1	SSRXn1	VBUS	SBU2	Dn2	Dp2	CC2	VBUS	SSTXn2	SSTXp2	GND

DRAWN/ DATE	设计 LYX	SIZE:A4	UNIT:MM.	PART. NO: 126-124-240001-H8G
CHECKED/ DATE	审核 HMY	SCALE: 1:1	PROJECTION	REV.: 版本
APPROVED/ DATE	核准 LJP	DWG. PATH	0482-1	SHEET: 页码



REV.	DESCRIPTION	NAME	DATE
A	NEWS ISSUE		

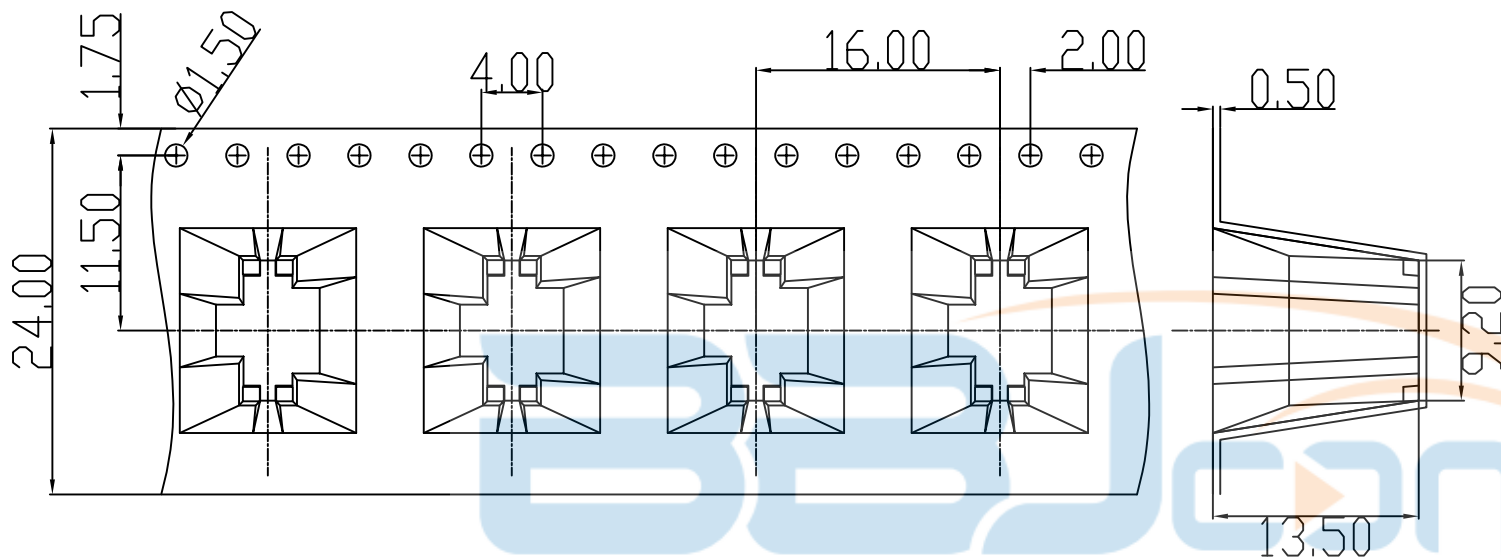

- 技术要求:
1. 圆孔十个孔距离累计允许公差为  $\pm 0.20\text{mm}$ .
  2. 带长250mm内容许弯曲度1mm.
  3.  $A_0/B_0$ 尺寸由槽底0.30mm高处定义之.
  4.  $K_0$ 尺寸由槽底内表面处至成型上表面处定义之.
  5. 所有尺寸定义依循EIA-481-C系准则定义之.
  6. 材料: 透明PET材质, 表面阻抗10-10  $\Omega$ .
  7. 材料厚度:  $0.50 \pm 0.05\text{MM}$ .
  8. 所用塑胶卷轮: 13"
  9. 13"单卷可装长度: 5.40 Meter.
  10. 13"单卷可装颗数: 300PCS.
  11. 未注明拔模斜度为 $5^\circ$ .

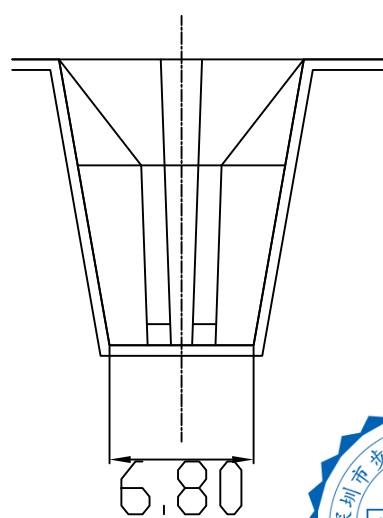

贴片出料方向

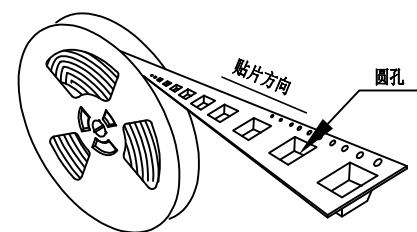
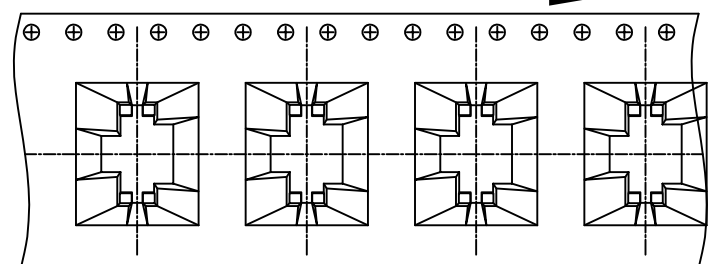

公差尺寸表 Tolerance		深圳市步步精科技有限公司					
X ±0.50 X' ±2°		TITLE: TYPE-C 24P 直立式公头 H=11.1 双排SMT 三脚插 带定位柱					
.X ±0.30 .X' ±1°		DRAWN/ DATE	设计 LYX	SIZE:A4	UNIT:MM.	PART. NO: 126-124-240001-H8G	
.XX ±0.10 .XX' ±0.5°		CHECKED/ DATE	审核 HMY	SCALE: 1:1	PROJECTION	REV.: 版本	
.XXX ±0.05		APPROVED/ DATE	核准 LJP	DWG. PATH	0482-1	SHEET: 页码	