

REV.	ECN NO	CONTENT	DATE	ENGINEER
A0				

SPECIFICATION:

- ELECTRICAL CHARACTERISTICS:
  - CURRENT RATING: 3A
  - TEMPERATURE RANGE: -40 ° C ~ 85 ° C
  - CONTACT RESISTANCE: 30 MILLIONHM MAX.
  - DIELECTRIC WITHSTANDING VOLTAGE: 100 VAC r. m. s
  - INSULATION RESISTNACE: 100 MEGOHMS MIN.
- MECHANICAL CHARACTERISTICS
  - INSERTION FORCE: 5~20N
  - EXTRACTION FORCE: Initial:8~20N, ATER TEST 6~20N
  - DURABILITY: 10, 000CYCLES
- THE SHELL LENTH IS LESS THAN THE MINIMUM SPECIFIED BY THE USB TYPE C STANDARD. AS SUCH IS CONNOT INDENOENDENTLY BE GUARANTEED TO MEET ALL TYPE C MECHANICAL REQUIREMENTS.

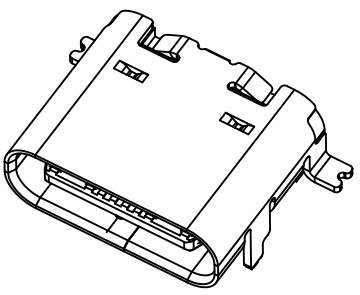
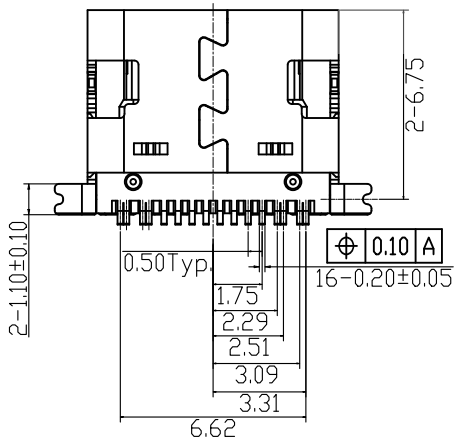
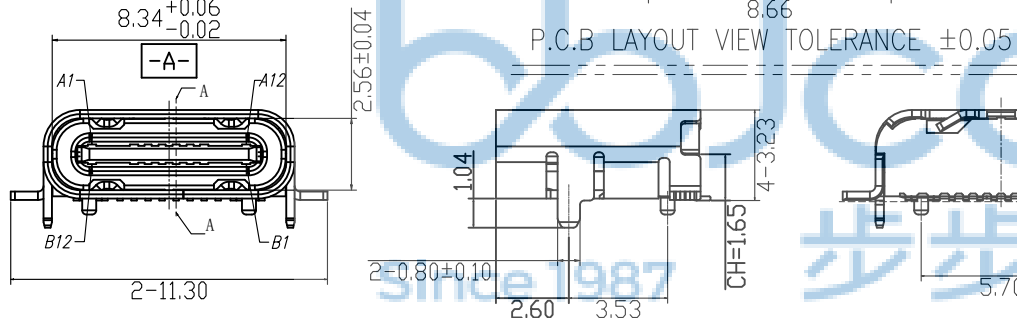
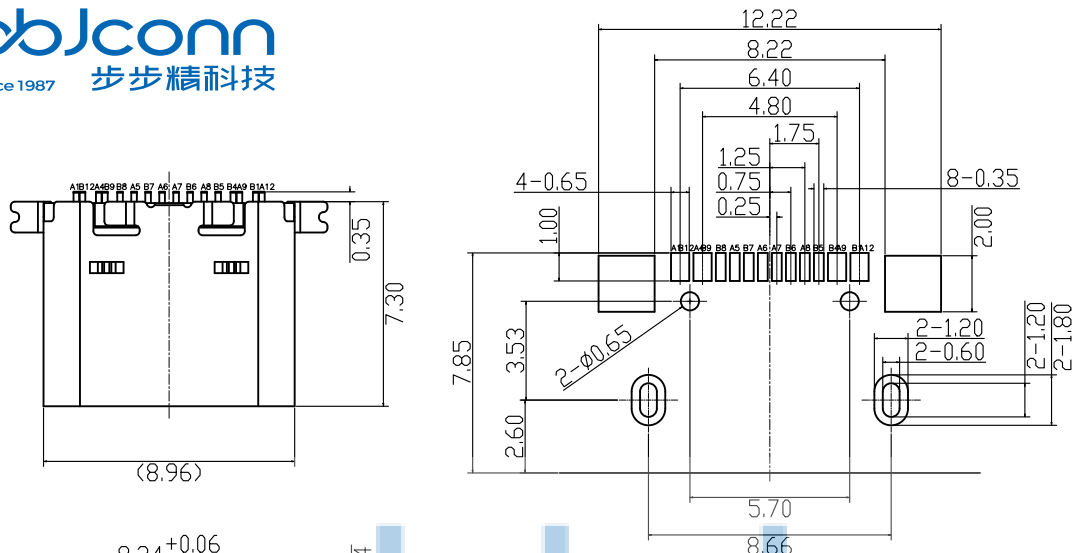

USB TYPE-C PIN ASSIGNMENTS

PIN NUMBER	A1	A2	A3	A4	A5	A6	A7	A8	A9	A10	A11	A12
SIGNAL NAME	GND			V <sub>BUS</sub>	CC1	Dp1	Dn1	SBU1	V <sub>BUS</sub>			GND
PIN NUMBER	B12	B11	B10	B9	B8	B7	B6	B5	B4	B3	B2	B1
SIGNAL NAME	GND			V <sub>BUS</sub>	SBU2	Dn2	Dp2	CC2	V <sub>BUS</sub>			GND

NO.	DESCRIPTION	QTY.	MATERIAL	FINISHED
4	OUT_SHELL	1 PCS	STAINLESS STEEL SUS301	Ni Plated
3	CONTACT	1 SET	COPPER ALLOY C7025	Au & Ni Plated
2	MOLDING HOUSING	1 PCS	PLASTIC LCP	None
1	SHELL	1 PCS	STAINLESS STEEL SUS304	Ni Plated

THIS DOCUMENT IS THE SOLE PROPERTY OF BBJconn Technology Co.,Ltd. Corporation AND SHOULD NOT BE USED IN WHOLE OR IN PART WITHOUT PRIOR WRITTEN PERMISSION.

PDWG.NO: 0482-1

APPD. JM\_Zheng

CHKD. LYX

DR. TSP

NAME: TYPE-C 16P 母座 L=7.30 CH=1.65 板上型 带柱 外壳脚前插后贴 端子SMT

PJ. NO.: 126-221-160006-H8G

SIZE: A4 DRW NO.:

FINISH: SEE NOTES MAT'L.: SEE NOTES

SCALE: N/A REV.: A0 UNIT: mm PAGE: 1/2

**深圳市步步精科技有限公司**

REV.	ECN NO	CONTENT	DATE	ENGINEER
A0				

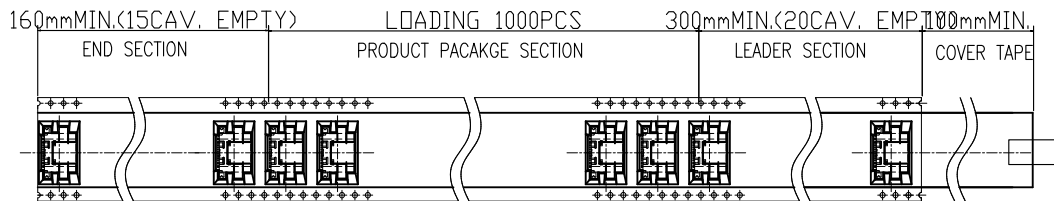

NOTES 2:

- MATERIAL:
  - REEL AND AXLE: PS, BLUE
  - CARRIER TAPE: PET, LUCID
  - COVER TAPE: PS, TRANSPARENT
  - SHIPPING CARTON: CORRUGATED FIBER
- DIMENSION:
  - REEL: W=24.5, ØA=330
  - CARRIER TAPE: T=0.30 W=24.0
  - COVER TAPE: T=0.05 W=21.5
  - SHIPPING CARTON: L=335mm, W=335mm, H=425mm
- QUANTITY :
  - PRIMAY PACKING: 1000PCS/REEL
  - SECONARY PACKING: 12 REELS/CARTON (12000PCS/CARTON)
- PEELING RESISTANCE: 0.1~1.3N
  - PEELING SPEED: 300mm/minutes
  - PEELING ANGLE: 165°~180°

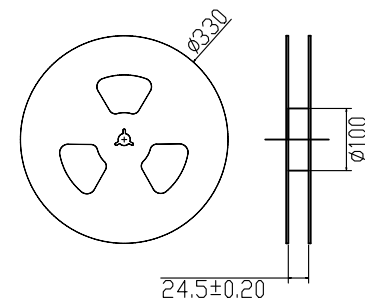
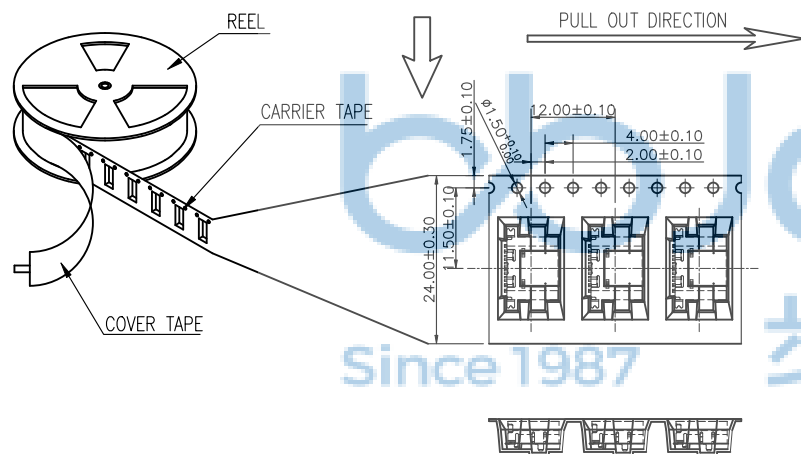

COVER TAPE

PLASTIC REEL

CARRIER TAPE

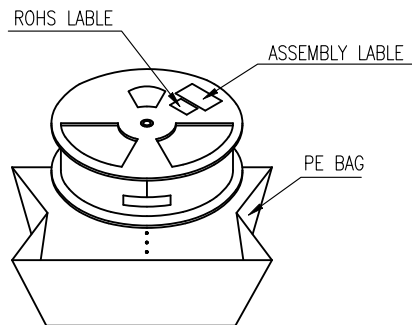

LIGHT LABEL

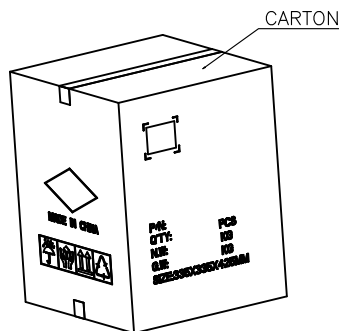

THIS DOCUMENT IS THE SOLE PROPERTY OF BBJconn Technology Co.,Ltd. Corporation AND SHOULD NOT BE USED IN WHOLE OR IN PART WITHOUT PRIOR WRITTEN PERMISSION.		深圳市步步精科技有限公司 .X: ±0.38    .X': ±3" .XX: ±0.25    .X'': ±2" .XXX: ±0.13    .X''': ±1"		NAME: TYPE-C 16P 母座 L=7.30 CH=1.65 板上型 带柱 外壳脚前插后贴 端子SMT	
APPD.	JM_Zheng	PJ. NO.: 126-221-160006-H8G		SIZE: A4   DRW NO.:	
CHKD.	LYX	FINISH: SEE NOTES		MAT'L.: SEE NOTES	
PDWG.NO:	0482-1	DR.	TSP	SCALE: N/A	REV.: A0   UNIT: mm   PAGE: 2/2