

REV.	ECN NO	CONTENT	DATE	ENGINEER
A0				

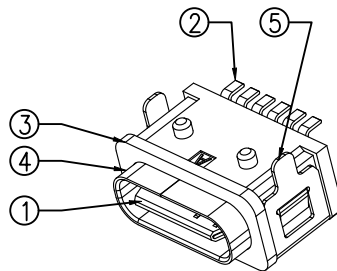
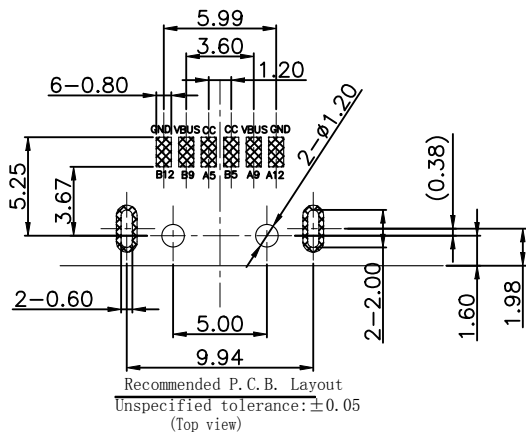
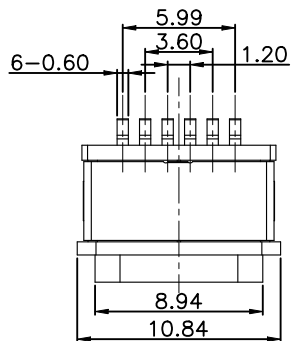

SPECIFICATION:

- CURRENT RATING: 3.0A MAX
- DIELECTRIC WITHSTAND VOLTAGE: 100VAC
- TEMPERATURE RANGE: -30 °C ~ 85 °C
- CONTACT RESISTANCE: 40 MILLIONHM MAX
- INSULATION RESISTANCE: 100 MEGOHMS MIN.
- INSERTION FORCE : 5N~20N
- UNMATING FORCE: 8N~20N
- DURABILITY: 10,000 CYCLES
- WATER PROOFNESS: THIS PRODUCT IS BASED ON IPX8.

结构设计注意:

- 成品使用时, 如有洗面奶泡沫、牙膏、洗手液、脏污液体, 请在TYPE-C口外面再设计一层外壳, 保护TYPE-C表面金手指不会被脏污覆盖。

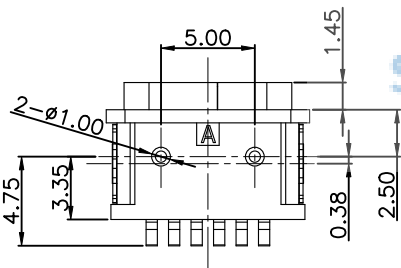
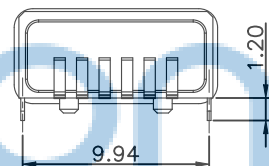
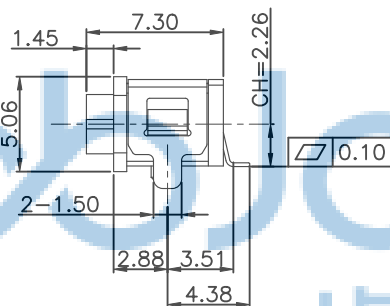
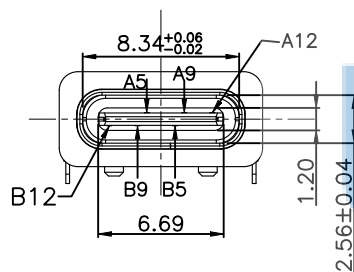

A5	CC1	B12	GND
A9	VBUS	B9	VBUS
A12	GND	B5	CC2
PIN	SIGNAL NAME	PIN	SIGNAL NAME



Since 1987

步步精科技

6	O-ring	1	SILICA GEL	BLACK
5	Shell2	1	SUS301 Ni Plating T=0.20mm	Ni:40~120u";
4	Shell1	1	SUS304 Ni Plating T=0.30mm	Ni:40~120u";
3	Housing2	1	PA10T(G.F30%)	
2	Contact	5	Phosphor bronze C5210R-EH Au/Ni Plating T=0.20mm	Ni:40~160u"; Au:CONTACT AREA:1u", OTHER AREA:G/F
1	Housing	1	PA10T (G.F30%)	
ITEM	PART NAME	Q' TY	FINISH	NOTE

THIS DOCUMENT IS THE SOLE PROPERTY OF BBJconn Technology Co.,Ltd. Corporation AND SHOULD NOT BE USED IN WHOLE OR IN PART WITHOUT PRIOR WRITTEN PERMISSION.  
PDWG.NO: 0514-1

深圳市步步精科技有限公司

NAME: TYPE-C 6P 防水母座 90度 板上两脚插 带柱 L=7.30 CH=2.26 带中央片 端子SMT IPX8 带O型防水圈  
APPD. JM\_Zheng  
CHKD. LYX  
DR. TSP  
PJ. NO.: 126-221-060001-N6G  
SIZE: A4 DRW NO.:  
FINISH: SEE NOTES MAT'L.: SEE NOTES  
SCALE: N/A REV.: A0 UNIT: mm PAGE: 1/2

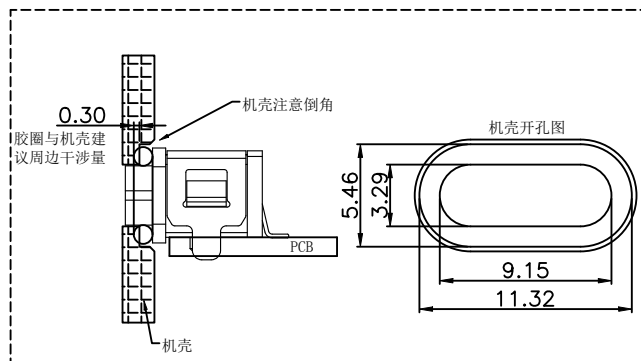
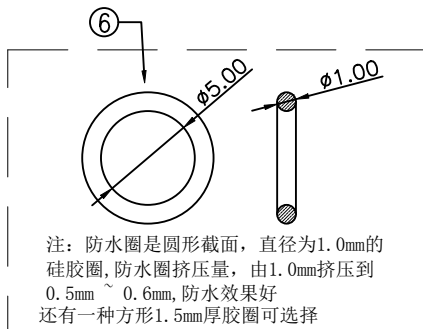

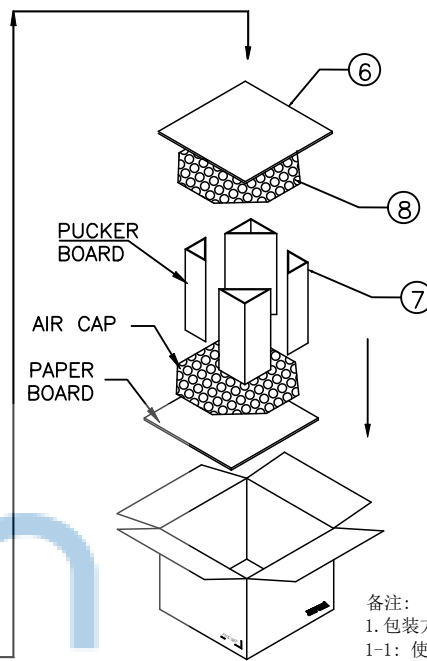
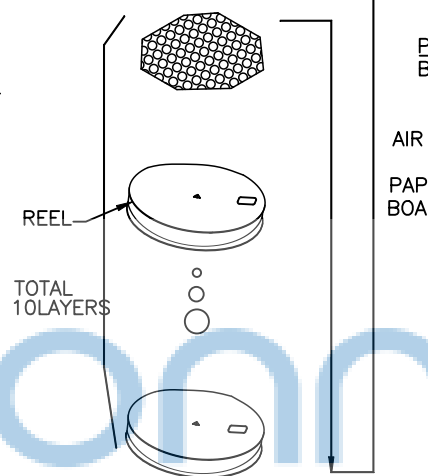
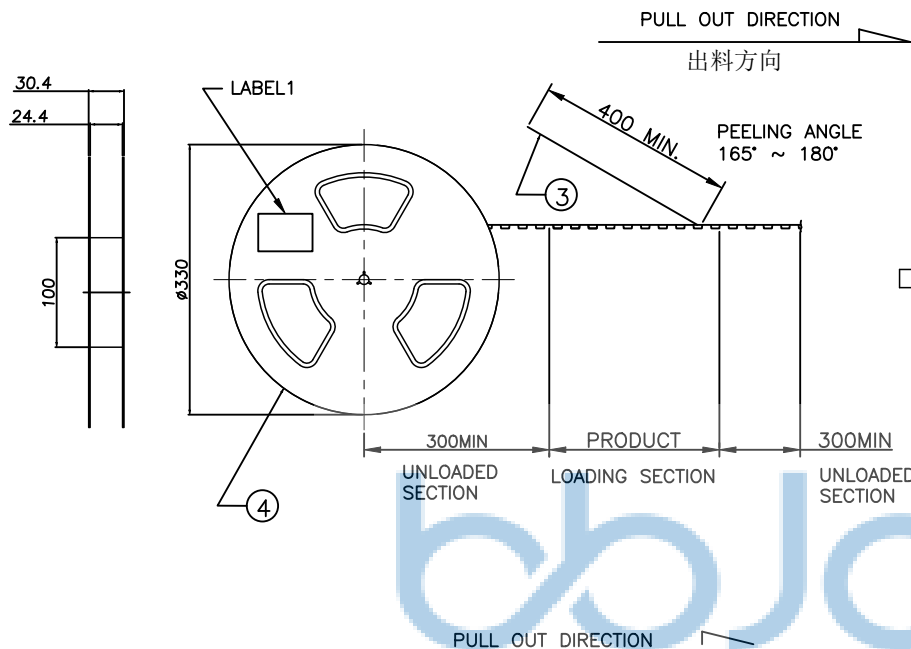

备注:  
1. 包装方式  
1-1: 使用半自动包装机, 先将 CARRY TAPE 送入导轨中, 并与 COVER TAPE 贴合在上面, 其中前端20空槽不要放产品, 尾端20空槽不要放产品, 然后将产品如图示方向依次放入 CARRY TAPE 每个槽放1PCS;  
1-2: 用胶带将 CARRY TAPE 压合在一起, 真空包装后在图示指定位置贴上 LABEL;  
1-3: 按图示要求将10盘包装好的 REEL 套入防水袋后装入纸箱, 纸箱上下按图示要求加垫硬纸板和海绵垫, 四角折三角垫固定;  
1-4: 将装好产品的纸箱按图示要求封箱, 在指定区域贴好 LABEL;  
2. 包装数量:  
600PCS/REEL;  
10REEL (6000PCS) /CARTON.  
3. 耐剥离性:  
上带引拔力测试规格: 20-150gf  
测试条件: 以每分钟300mm速度引拔测试

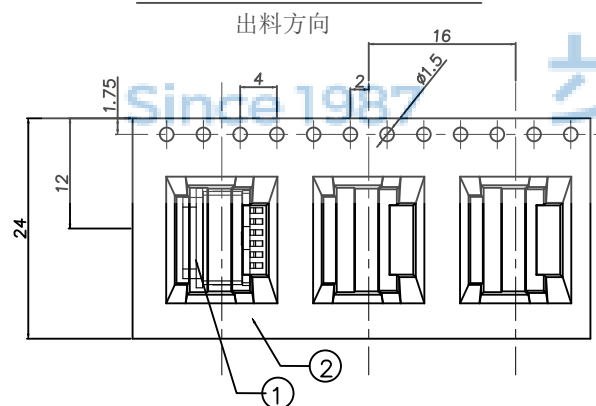

8	气泡垫	L=345,W=345,T=10	2PCS
7	纸板 (折三角垫)	L=430,W=330,T=6	4PCS
6	硬纸板	L=330,W=330,T=6	2PCS
5	外箱	L=350,W=350,H=330	1PCS
4	卷盘	PS,BLUE,A=330,B=100,W=32.4	10PCS
3	上带	PET,CLEAR,W=21.3	11.5m
2	载带	PS,BLACK,W=24,T=0.4,P=16	11.5m
1	UAB CONN	UAB CONN	6000PCS
NO.	NAME	SPEC	Q'TY



THIS DOCUMENT IS THE SOLE PROPERTY OF BBJconn Technology Co.,Ltd. Corporation AND SHOULD NOT BE USED IN WHOLE OR IN PART WITHOUT PRIOR WRITTEN PERMISSION.		<b>深圳市步步精科技有限公司</b> .X: ±0.38    .X': ±3' .XX: ±0.25    .X'': ±2' .XXX: ±0.13    .XX': ±1'	
APPD.	JM_Zheng	NAME:	TYPE-C 6P 防水母座 90度 板上两脚插 带柱 L=7.30 CH=2.26 带中夹片 端子SMT IPX8 带O型防水圈
CHKD.	LYX	PJ. NO.:	126-221-060001-N6G
DR.	TSP	SIZE:	A4 DRW NO.:
PDWG.NO:	0514-1	FINISH:	SEE NOTES
		MAT'L.:	SEE NOTES
		SCALE:	N/A
		REV.:	A0
		UNIT:	mm
		PAGE:	2/2